

Stereoelectronic Requirements of Fragmentation Reactions and Applications in Synthesis

Scott Peterson
Evans Group Seminar, March, 2005

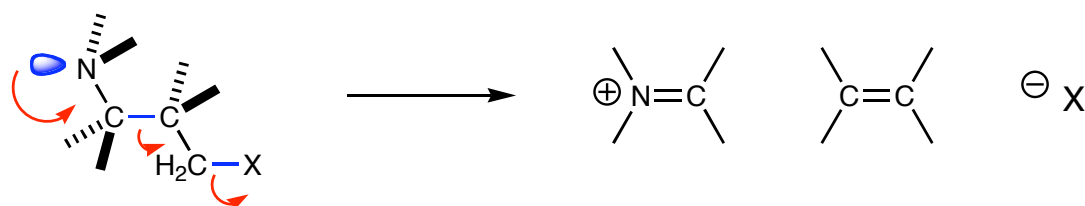
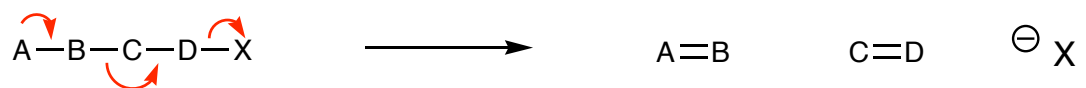

Key Words: Grob, Fragmentation, Marshall, Wharton, Nucleofuge, Electrofuge

Grob, C.A., *Angew. Chem. Int. Ed.*, **1967**, *6*, 1

Grob, C.A., *Angew. Chem. Int. Ed.*, **1969**, *8*, 535

Types of Fragmentation Reactions

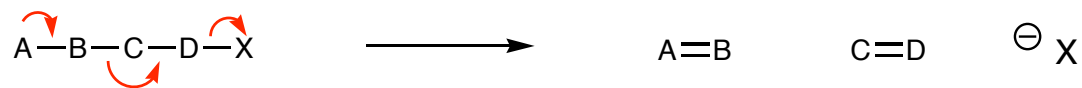

Electrofugal

Middle Groups

Nucleofugal

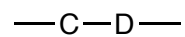
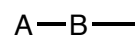

1,3 diols: Wharton

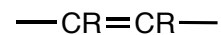
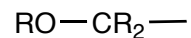
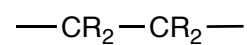

Eschenmoser

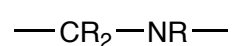
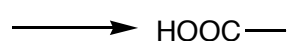

Grob

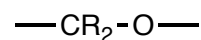
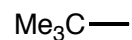
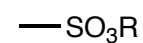
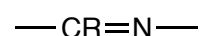
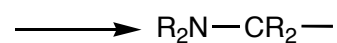

enolates: Mander

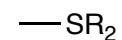
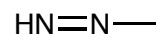
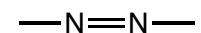
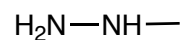
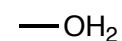
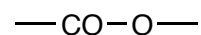
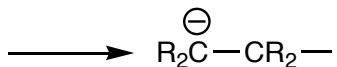

Marshall

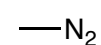

Fragmentations of Chloroamines

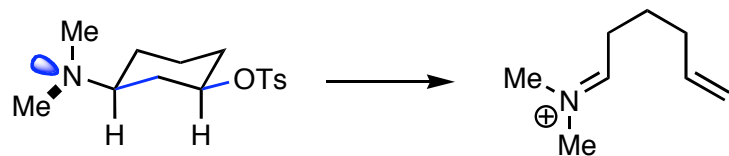
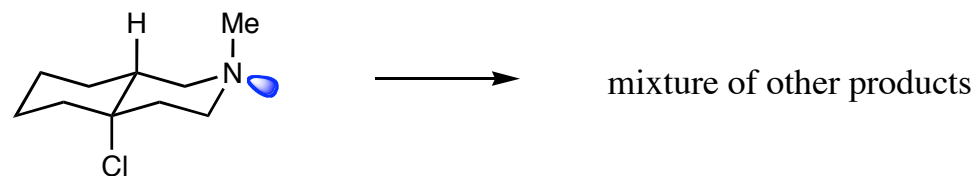
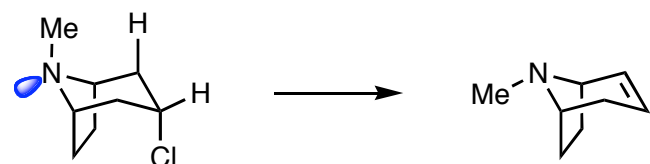
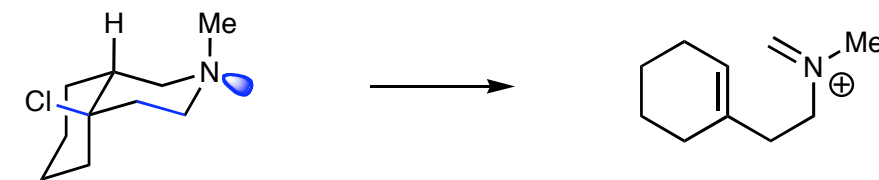
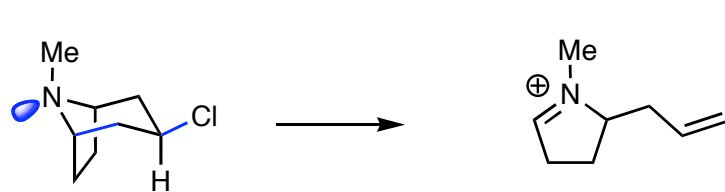

Frangomeric Effect: $k_f : k_i$

For all cases studied, $k_f : k_i > 10^2$
Some as high as 10^5

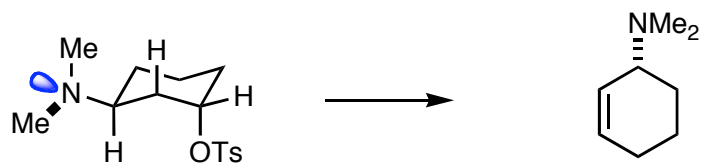

Fragmentation of Amino-Tosylates

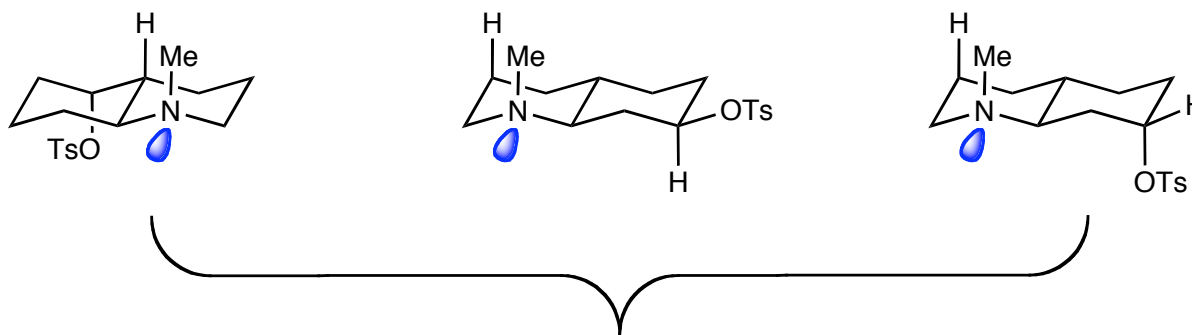
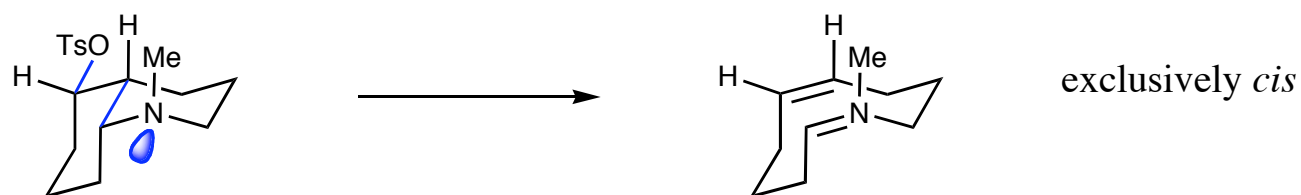
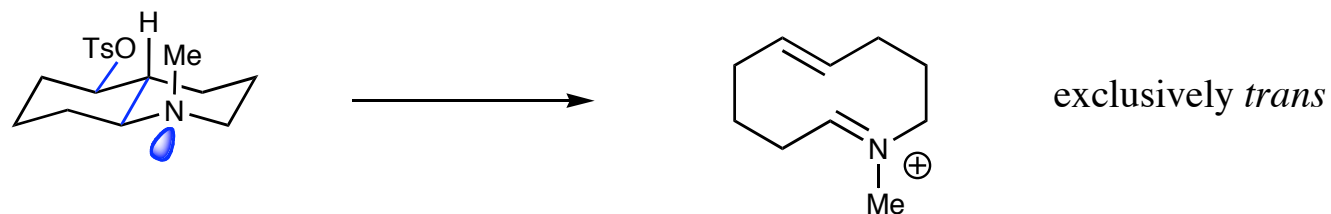

Fragmentation of Aza-bicyclo-tosylates

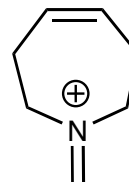
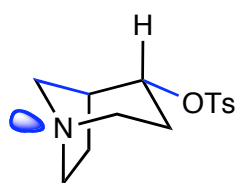
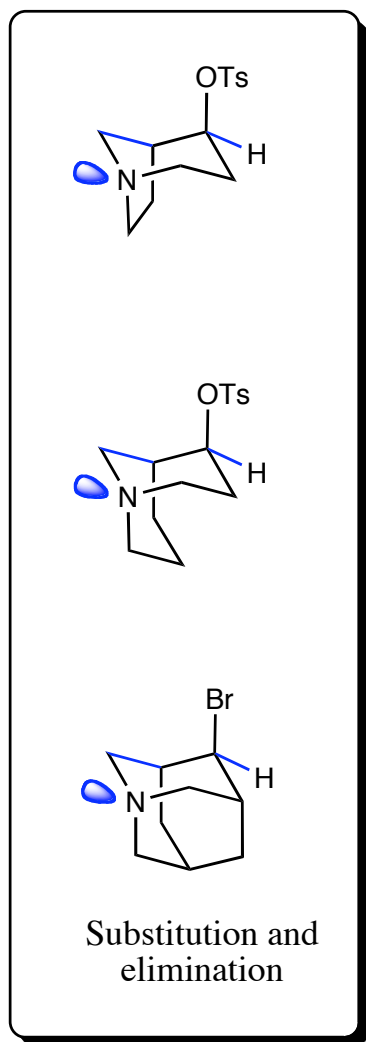

Reacts 10^3 times faster than carbon analogue

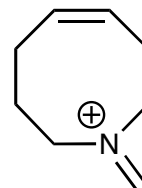
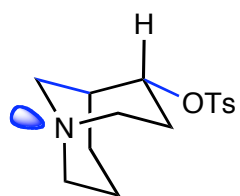

Reacts 10^4 times faster than carbon analogue

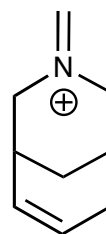
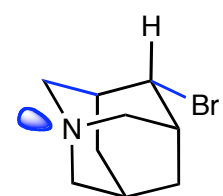

Reacts 10^5 times faster than carbon analogue

Decarboxylation Fragmentation

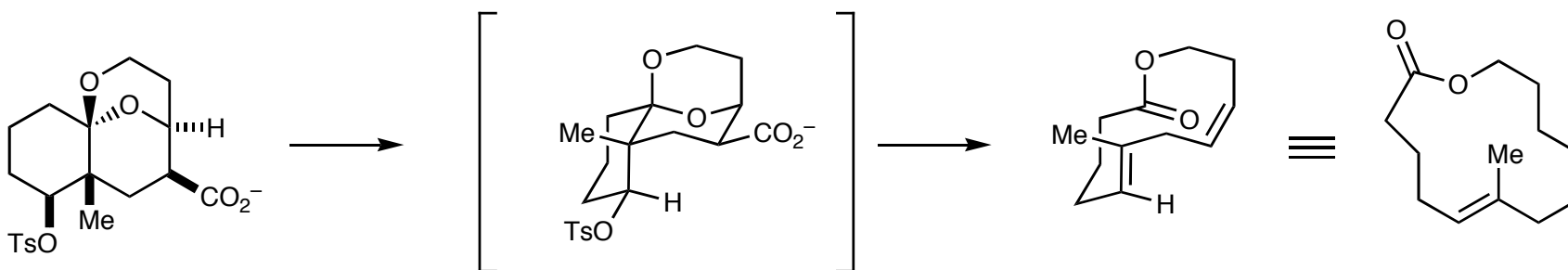
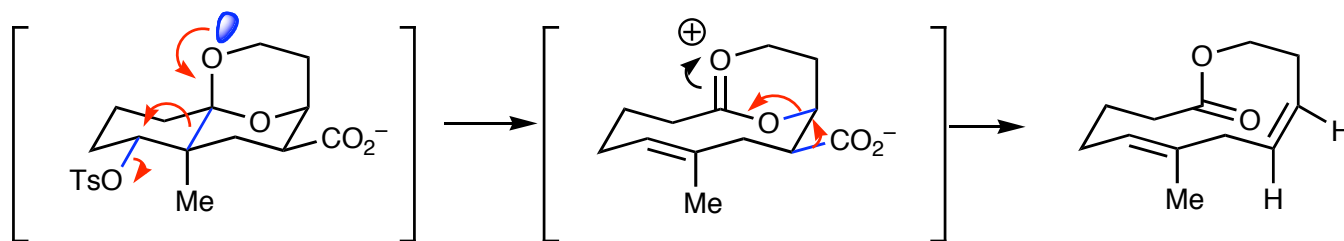
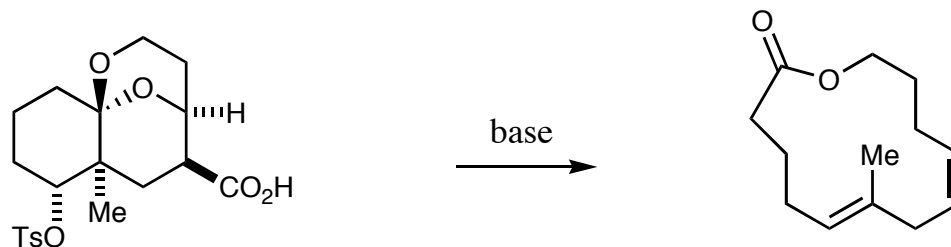

Decarboxylation Fragmentation

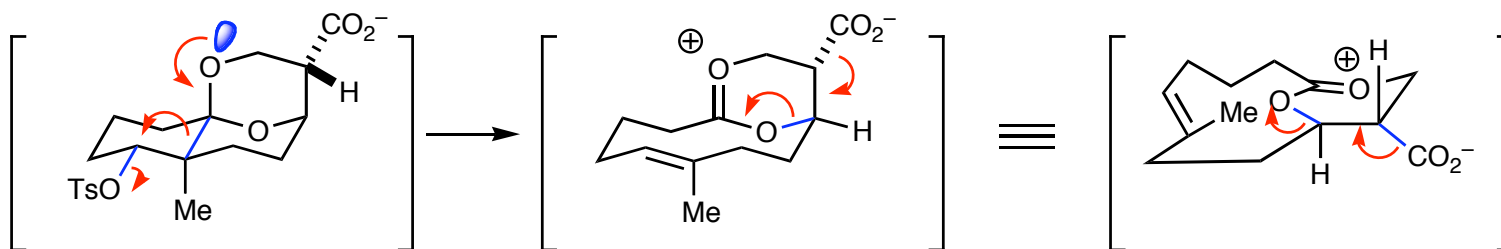
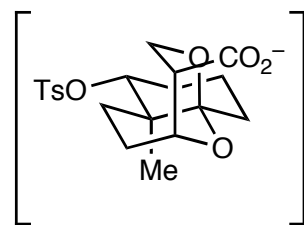
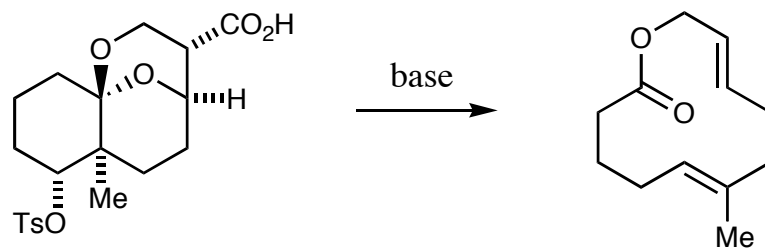

Eschenmoser, A., *Angew. Chem. Int. Ed.*, **1979**, *18*, 634

Eschenmoser, A., *Angew. Chem. Int. Ed.*, **1979**, *18*, 636

SmI₂ Cyclization / Grob Fragmentations

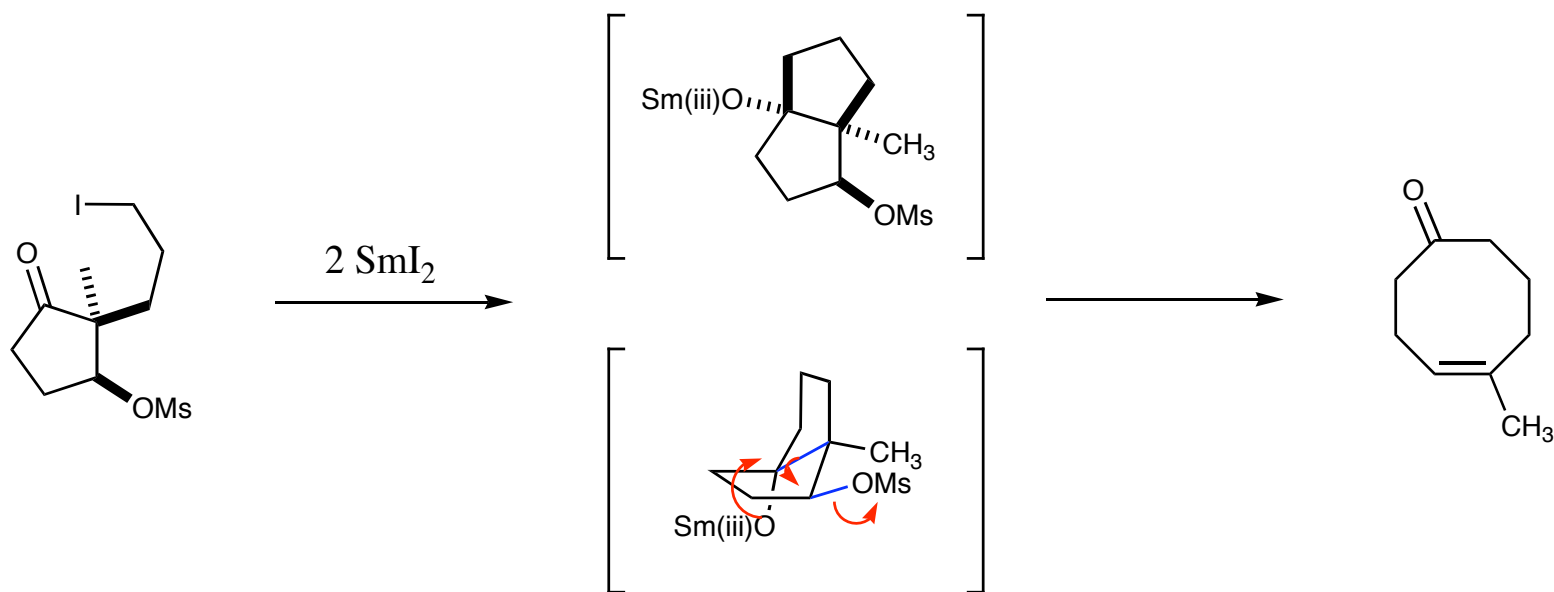

*Sml*₂ Cyclization / Grob Fragmentations

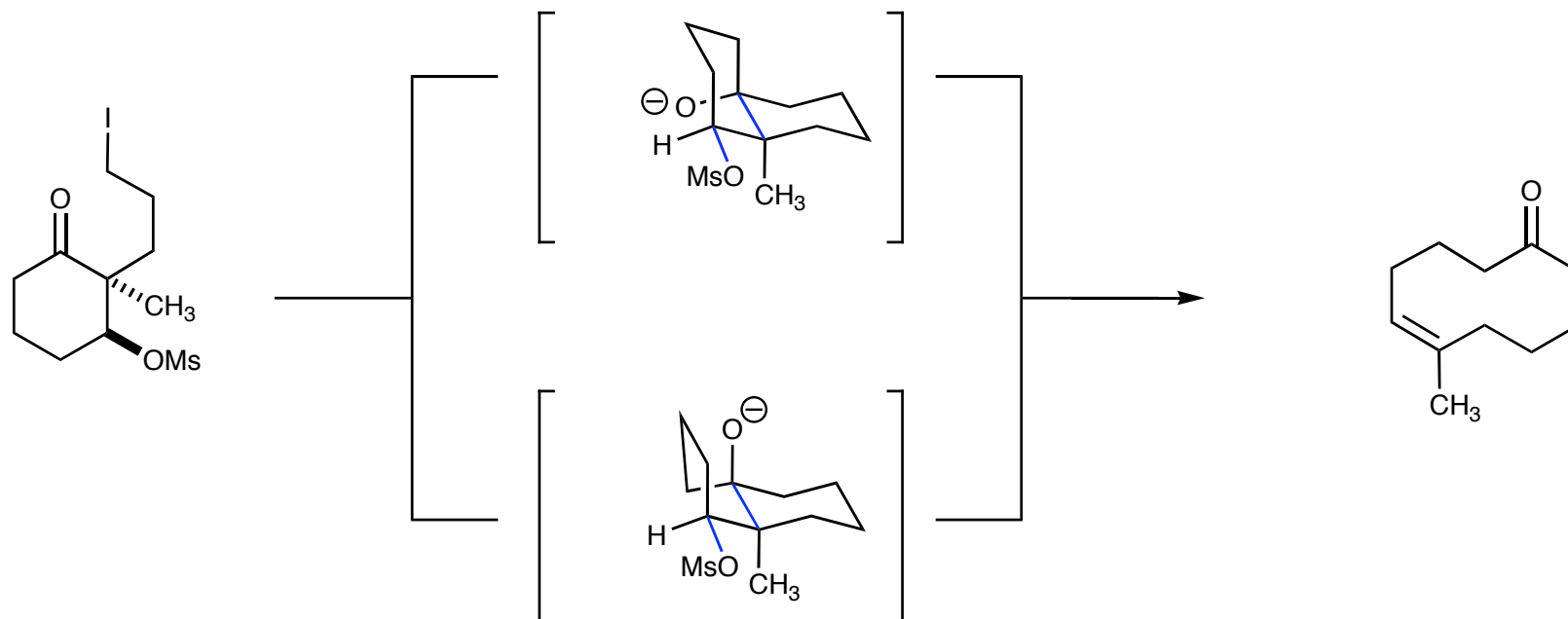

Scope of SmI_2 Cyclization / Grob Fragmentations

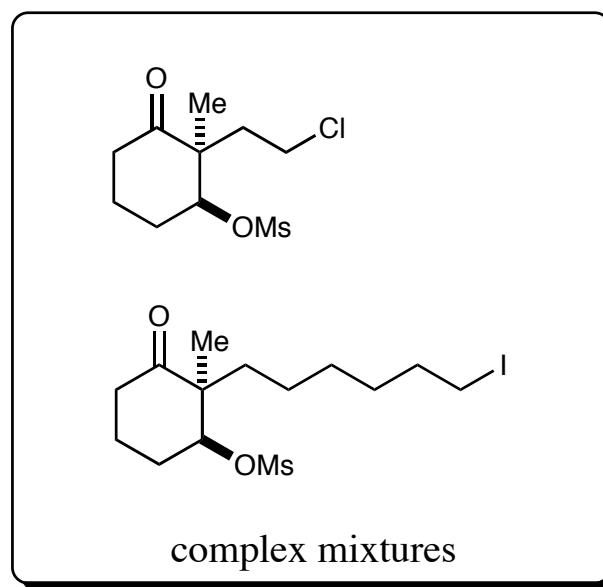
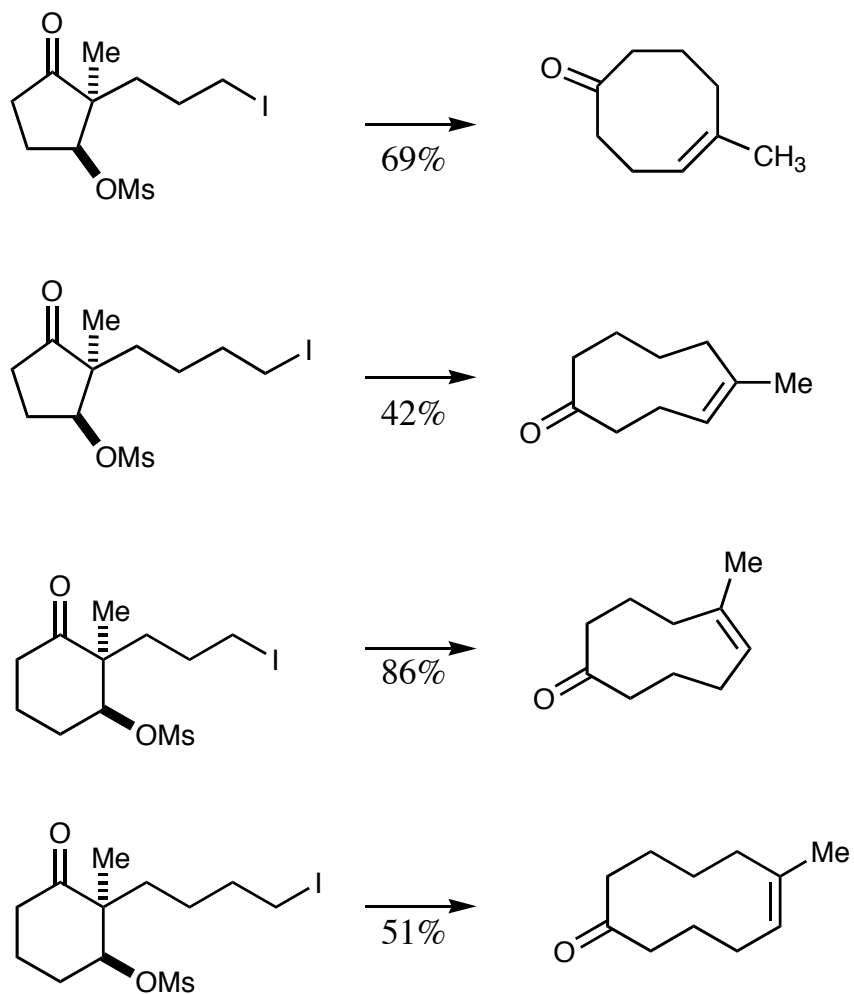

Reaction Conditions:

2.5 eq SmI_2 freshly prepared from Sm^0 and CH_2I_2

2 mol% NiI_2

THF, $-10\text{ }^\circ\text{C}$ to $0\text{ }^\circ\text{C}$ for 1 hour

SmI₂ Cyclization / Grob Fragmentations

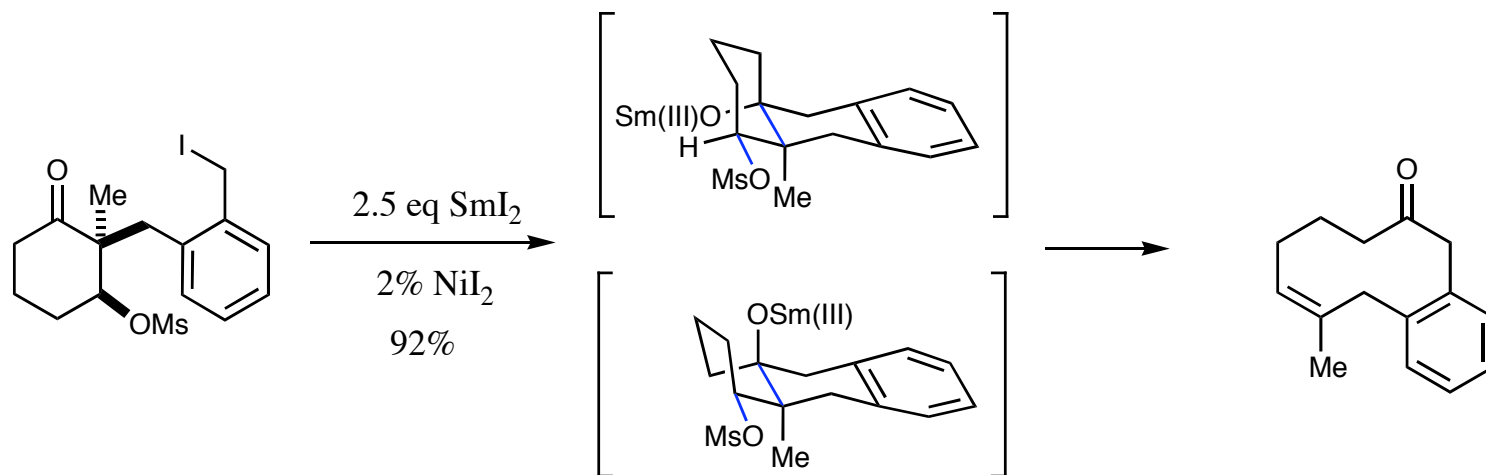
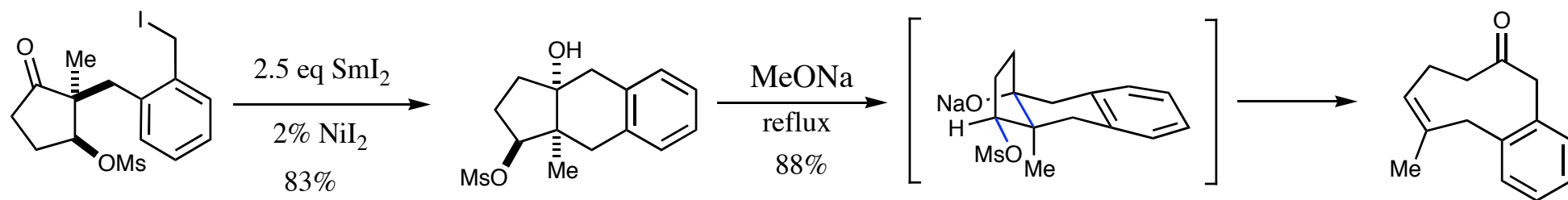

SmI₂ Cyclization / Grob Fragmentations

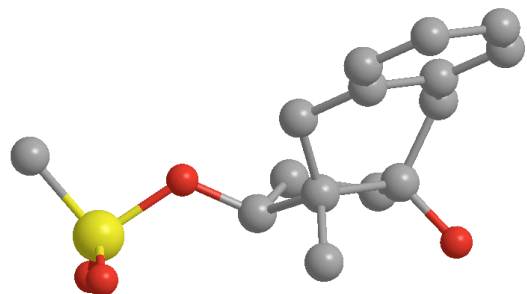
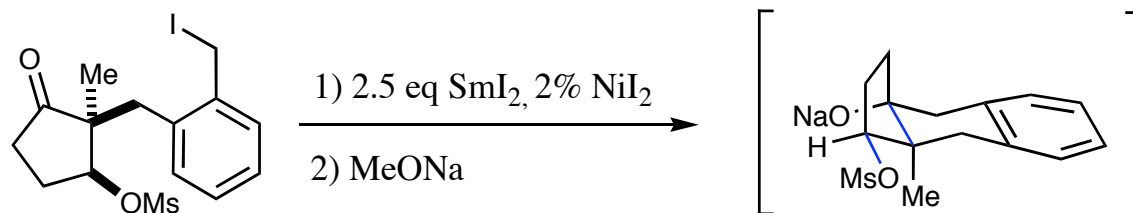

Ground state
dihedral angle = 143.8°

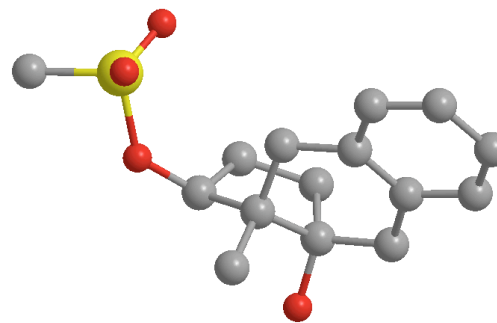

Possible transition state
dihedral angle = 175.4°

Relative energy = 6.50 kcal/mol

SmI₂ Cyclization / Grob Fragmentations

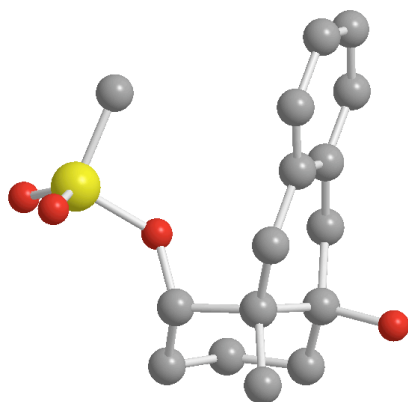
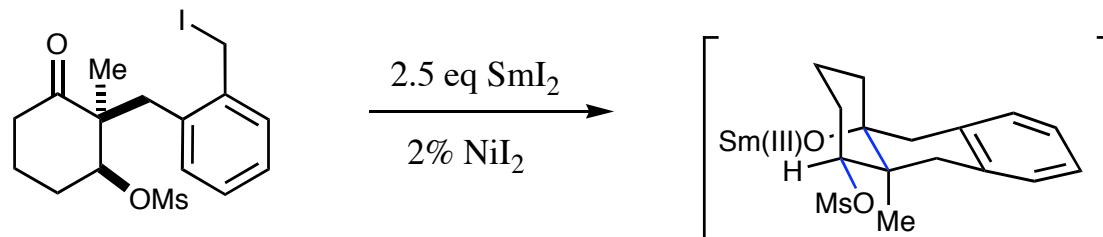

dihedral angle = 72.9°

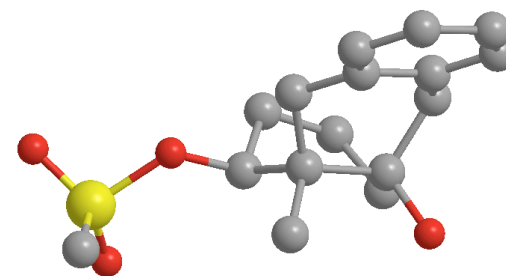

dihedral angle = 173.8°

Relative energy = 1.38 kcal/mol

Total Synthesis of (+)-Allocyathin

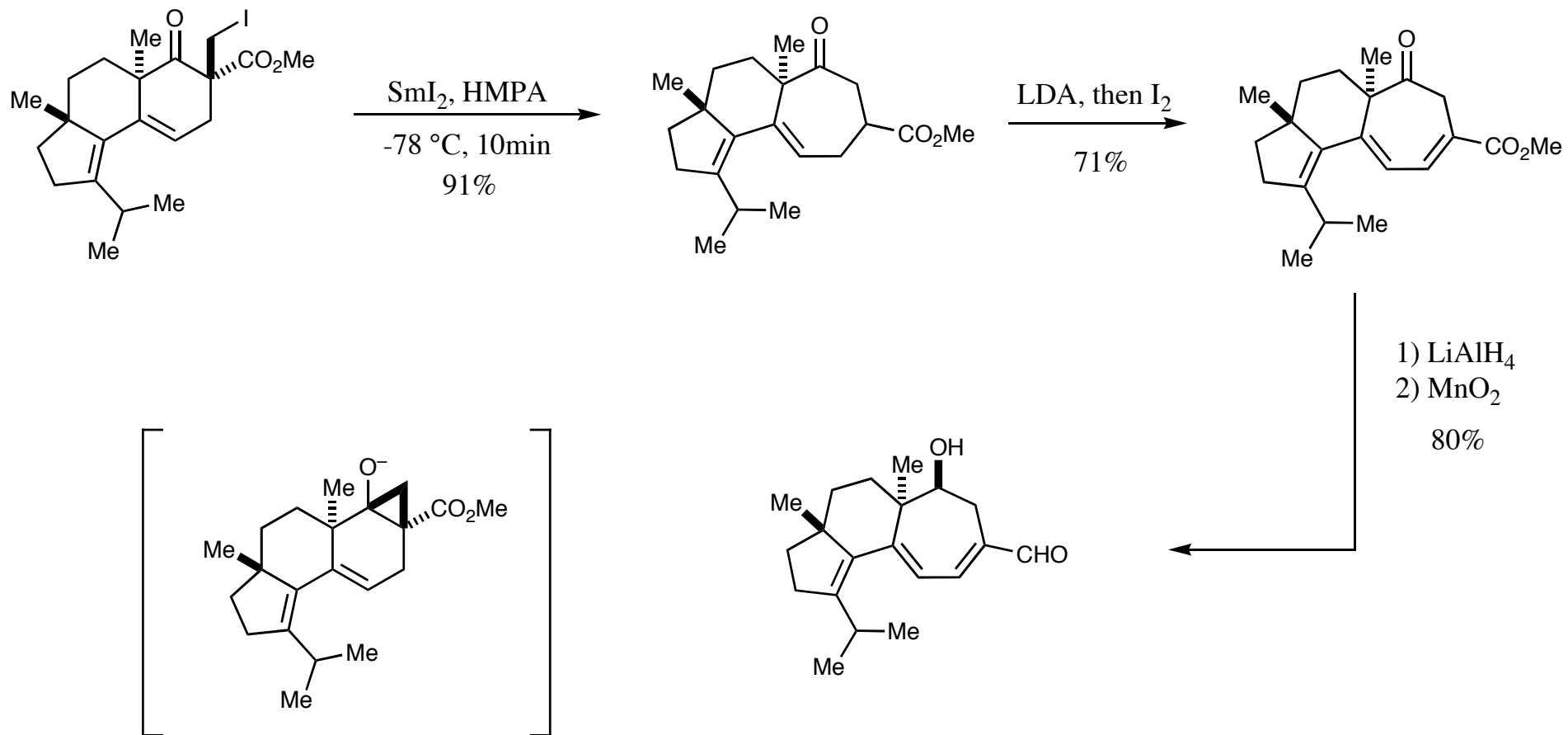

Nakada, M., et al., *Org. Lett.*, **2004**, *6*, 4897
Hasegawa, E., et al., *Tet. Lett.*, **1998**, *39*, 4059

Marshall Fragmentation

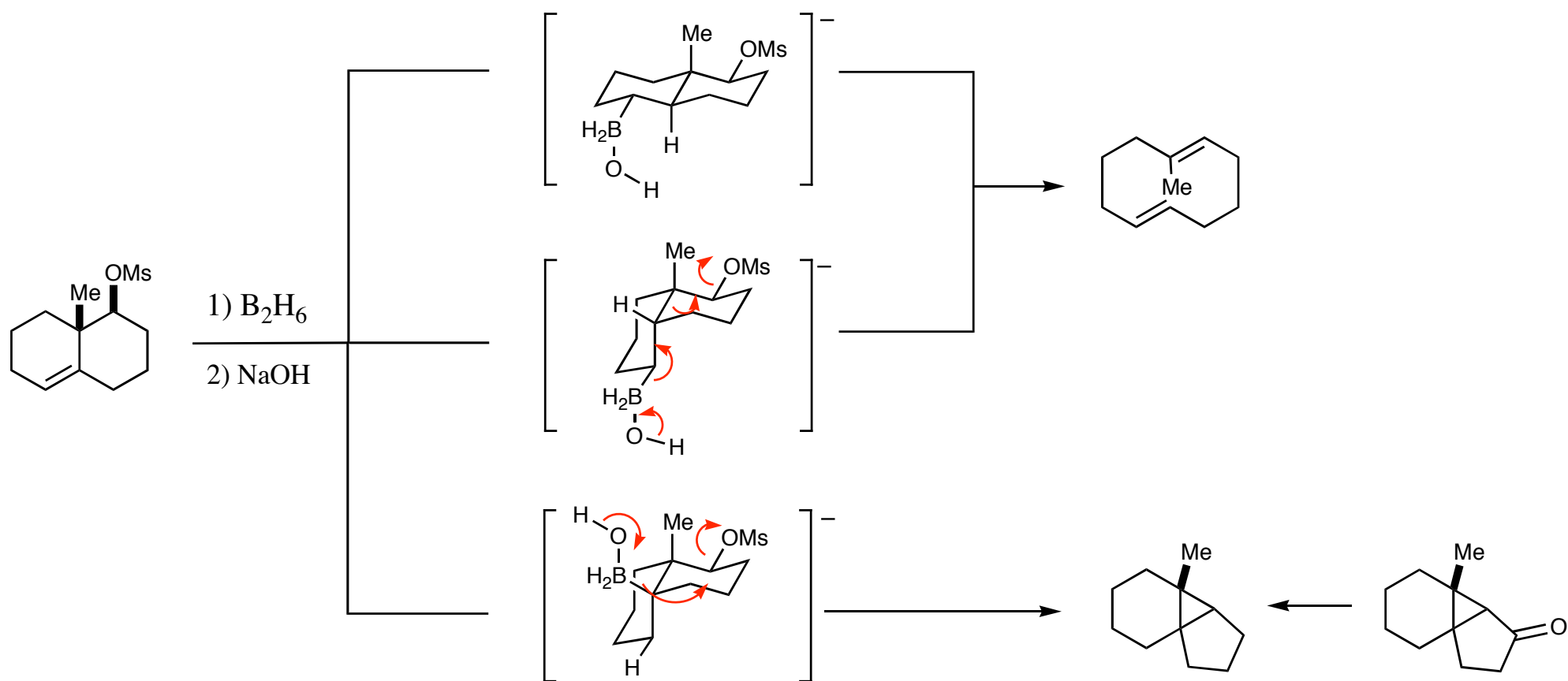

Synthesis of Allohedycaryol

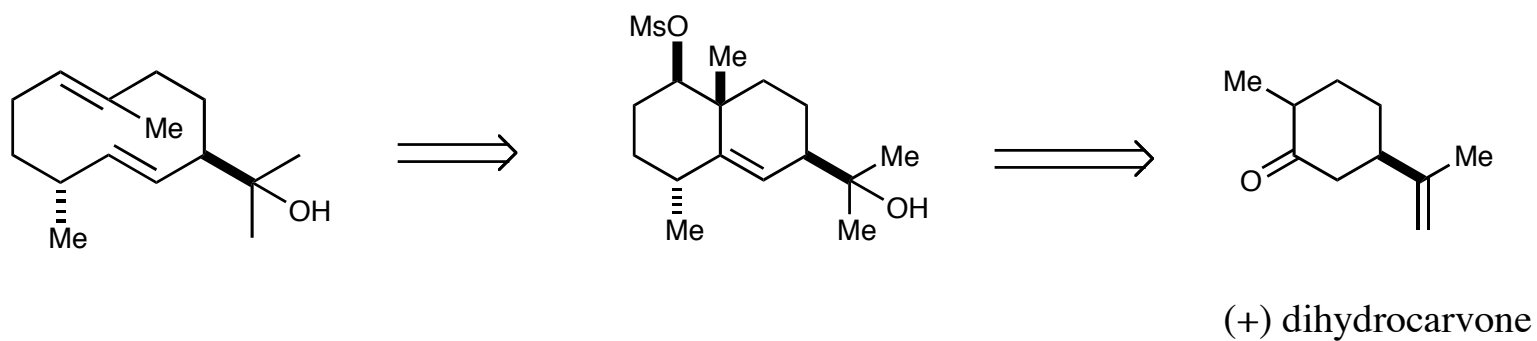

- Regioisomer of (+)-hedycaryol
- Isolated from *F. communis* L. (giant fennel)
- Toxic to livestock
- Widespread in the Mediterranean area

Synthesis of Allohedycaryol

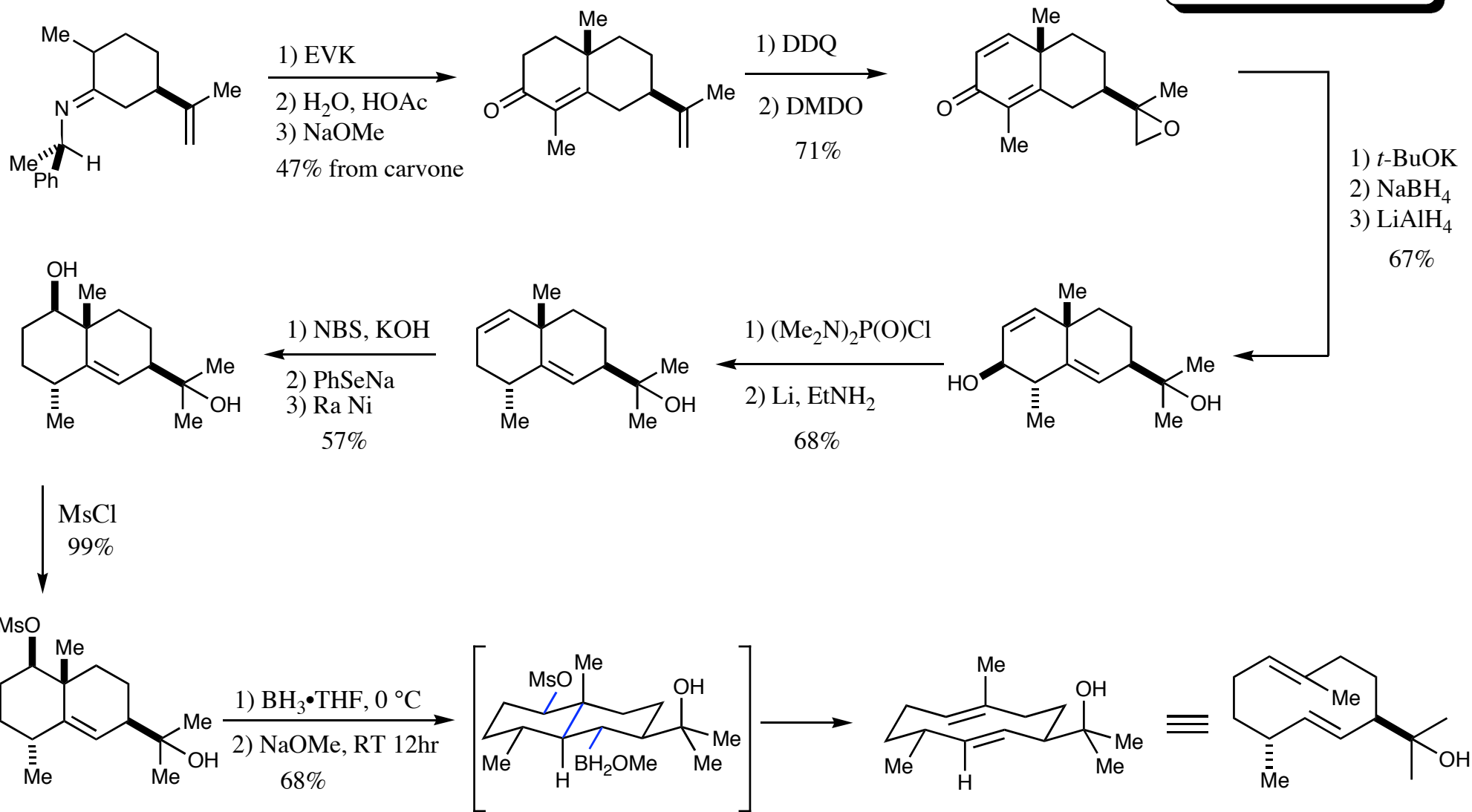
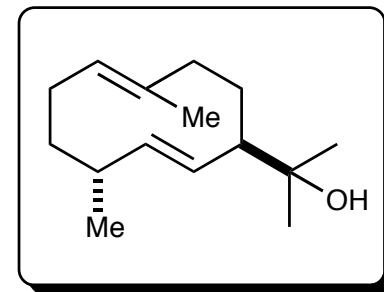

Wharton Fragmentation of 1,3 Diols

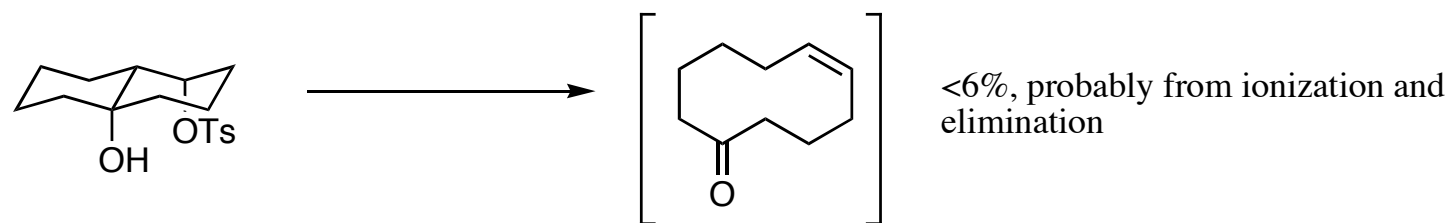
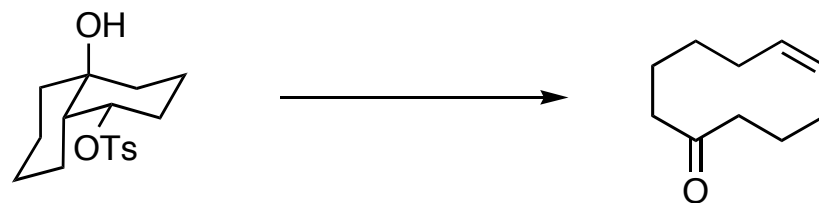
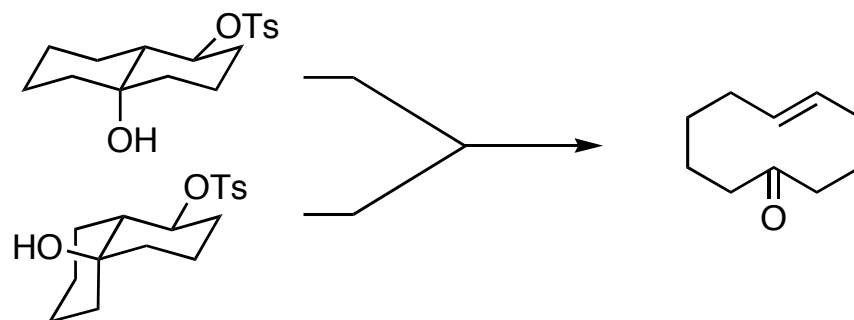

Wharton, P.S., *J. Org. Chem.*, **1961**, *26*, 4781

Wharton, P.S., *J. Org. Chem.*, **1963**, *28*, 3217

Wharton, P.S., *J. Org. Chem.*, **1965**, *30*, 3254

Ryanodol to Anhydroryanodol

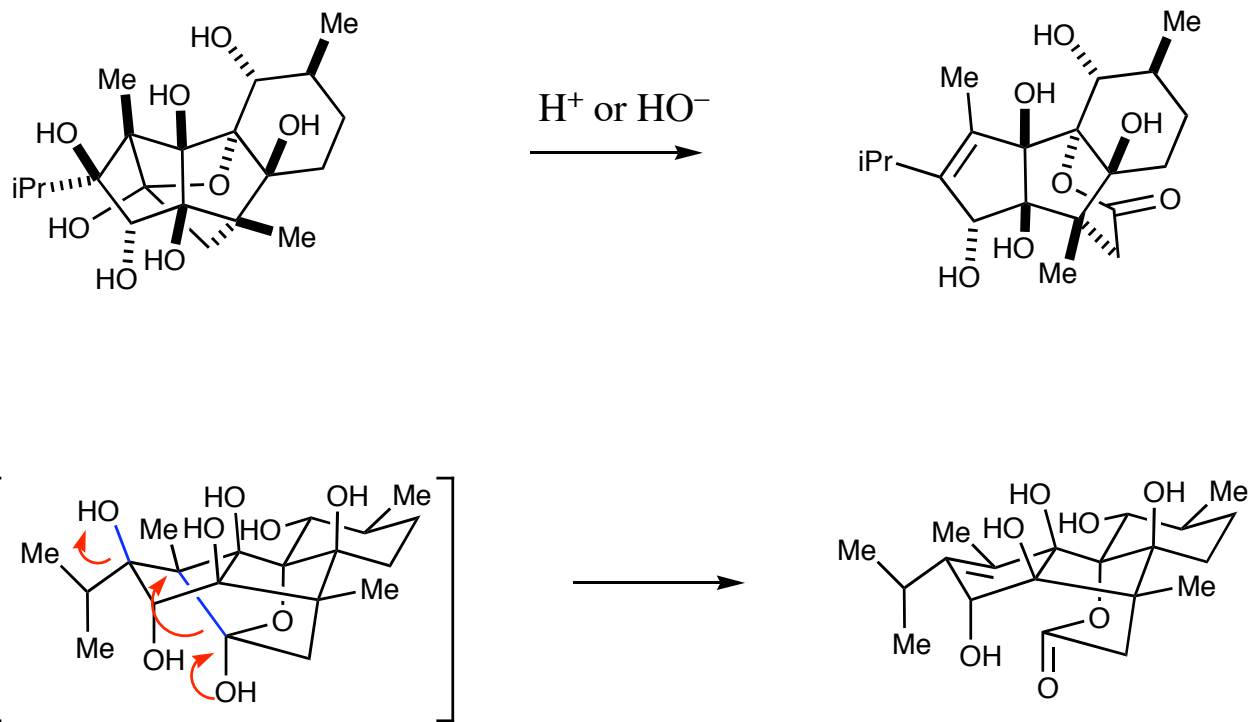

Weisner, K. *Adv. Org. Chem.*, 1972, **8**, 295
Deslongchamps, P., *Can. J. Chem.*, 1979, **57**, 3348
Weisner, K., *Tet. Lett.*, 1967, **3**, 221

Total Synthesis of Ryanodol

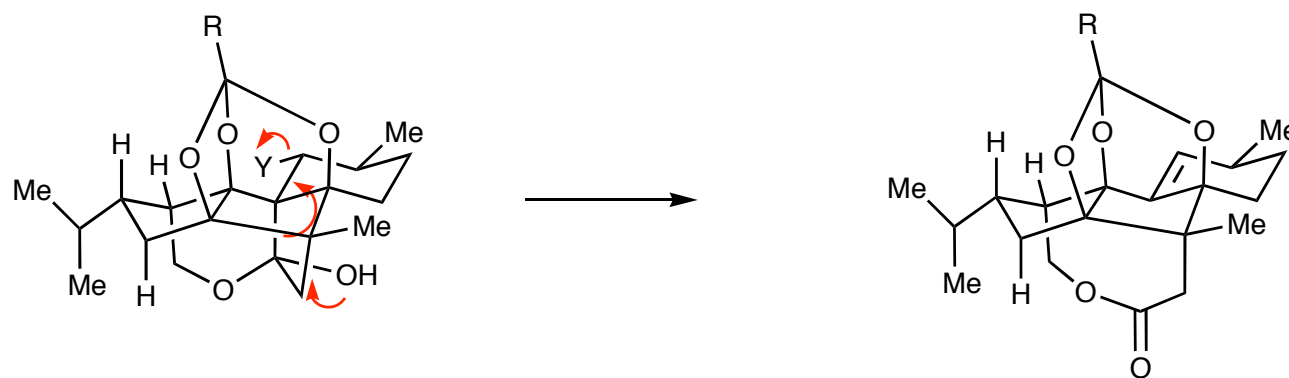

Synthesis of Zaragozaic Acid Core

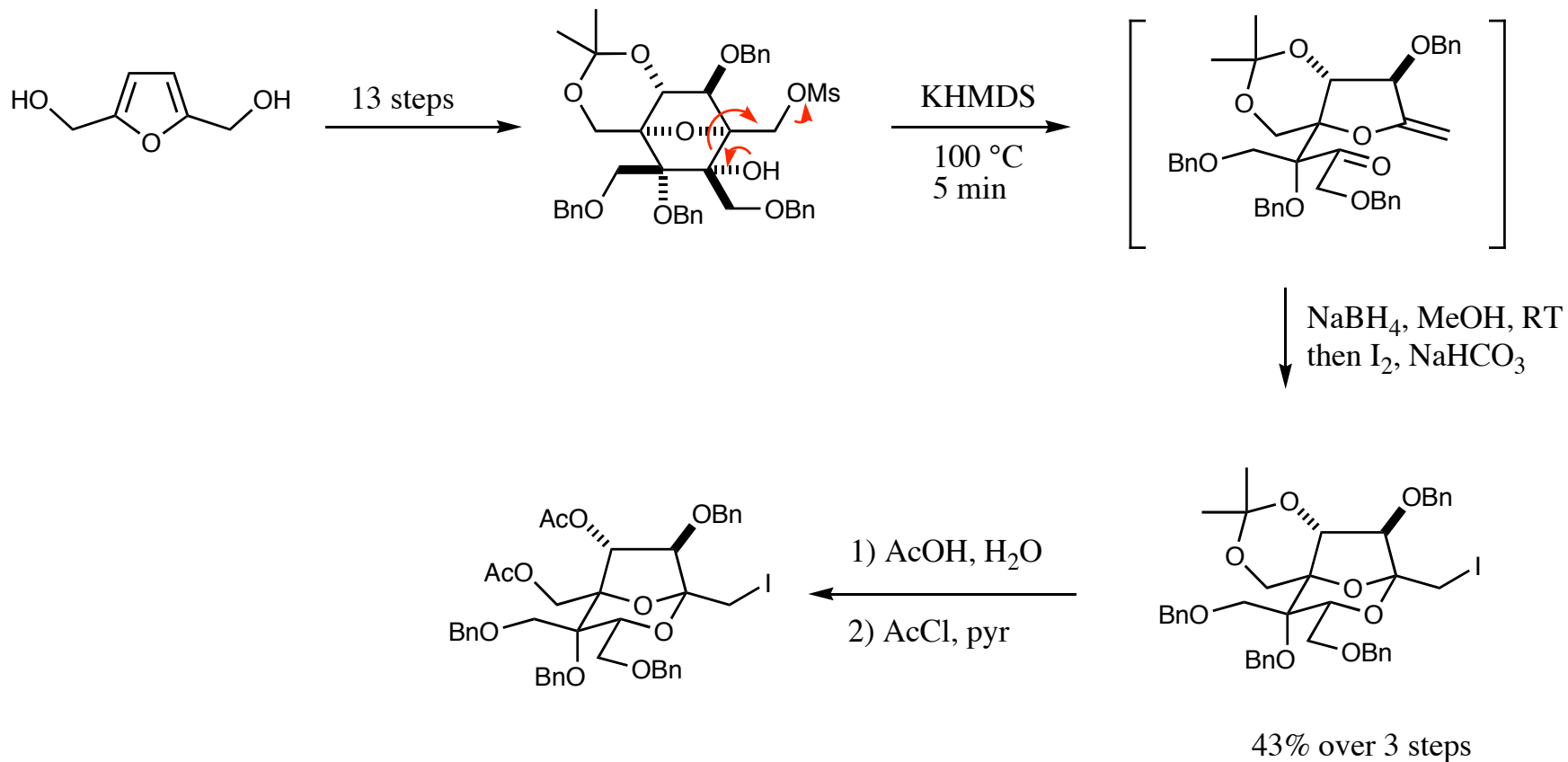

Synthesis of Jatrophatrione

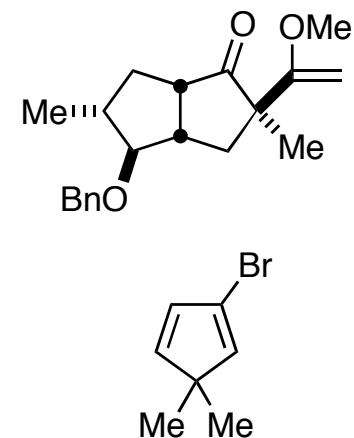
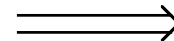
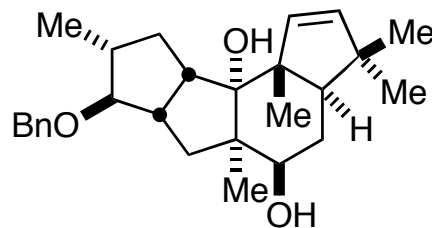
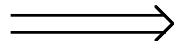
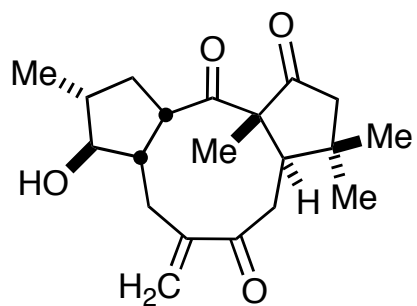

- isolated in 1976 from *Jatropha microrhiza*
- active against P-388 lymphocytic leukemia

Synthesis of Jatrophatrione

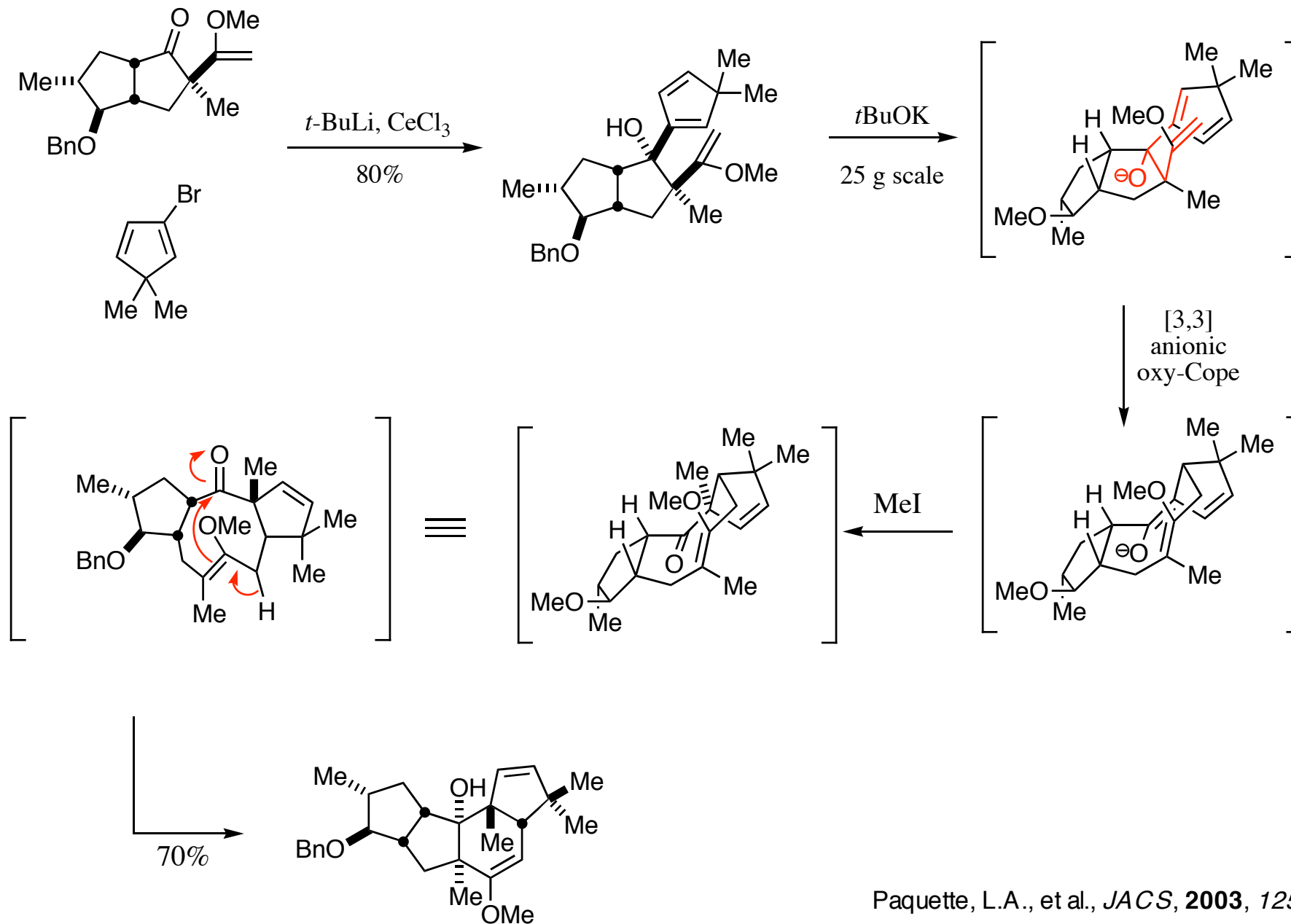

Synthesis of Jatrophatrione

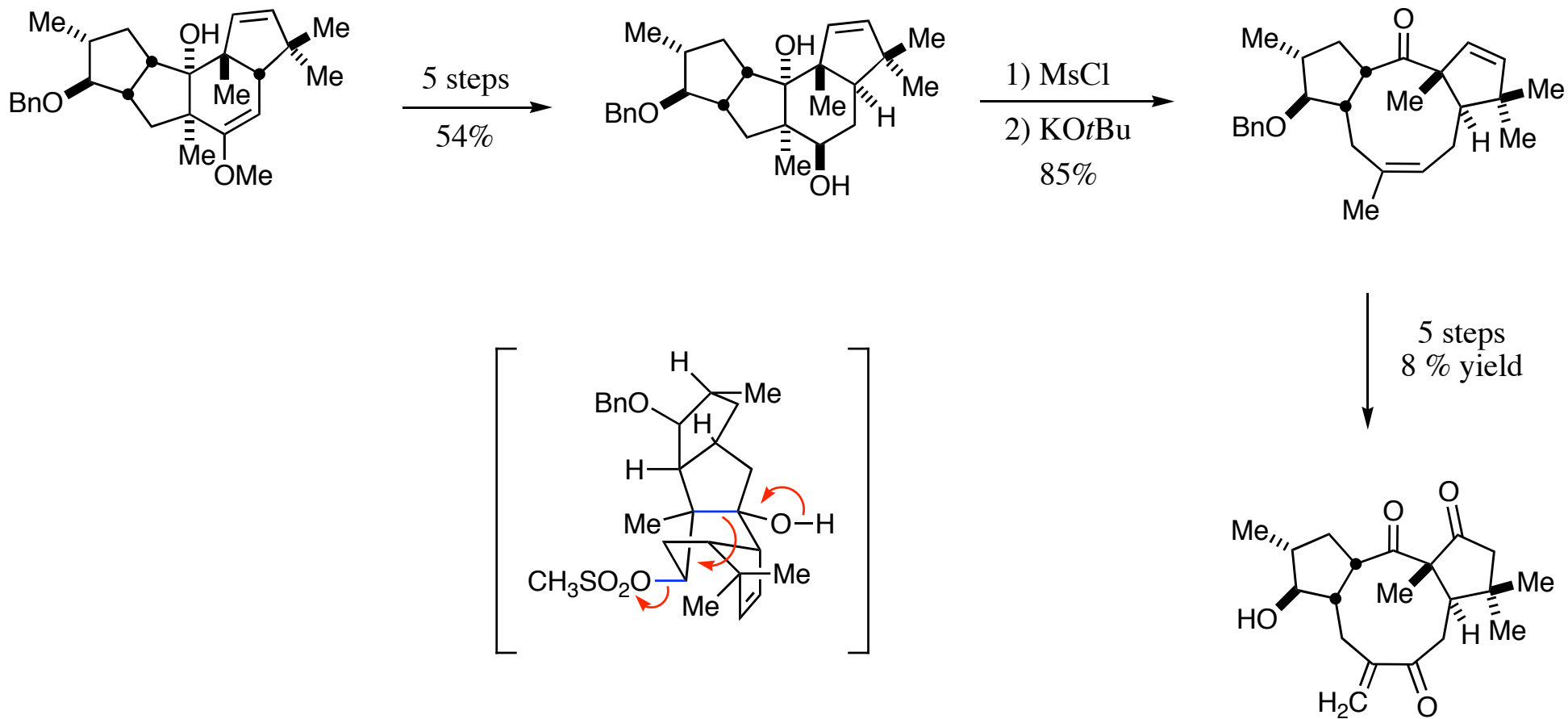

Paquette, L.A., et al., *J. Org. Chem.*, **1999**, *64*, 3244

Paquette, L.A., et al., *J. Org. Chem.*, **1999**, *64*, 3255

Synthesis of Coraxeniolide-A

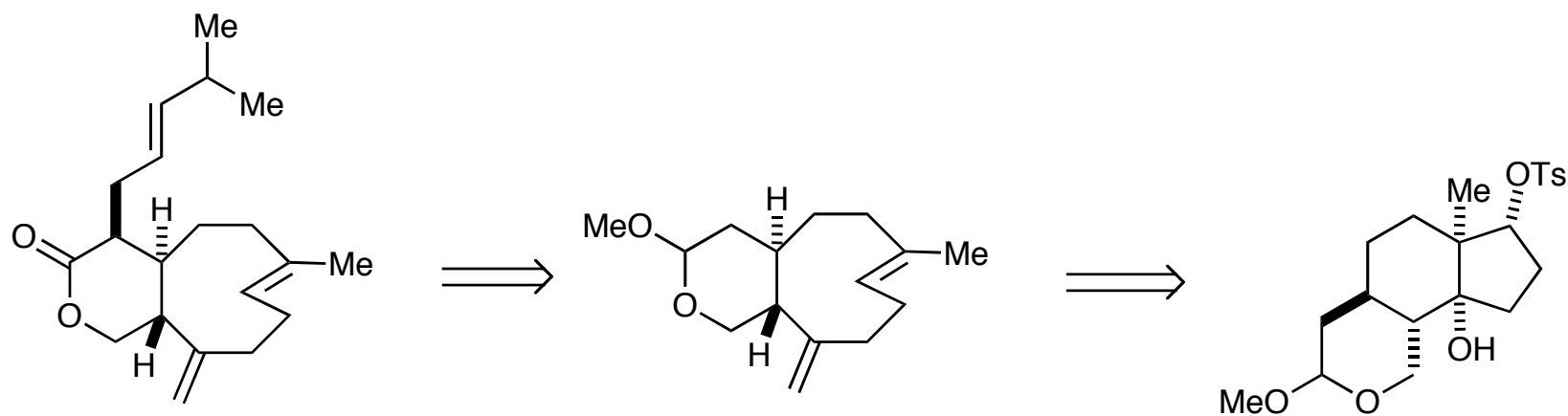

- From the xenicane family
- Isolated in 1981 from a pink coral

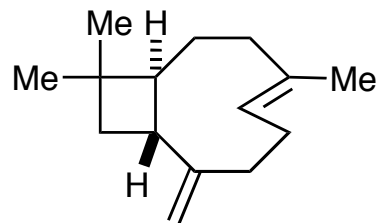

caryophyllene

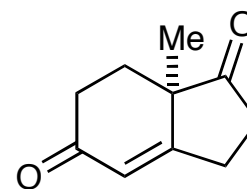

Synthesis of Coraxeniolide-A

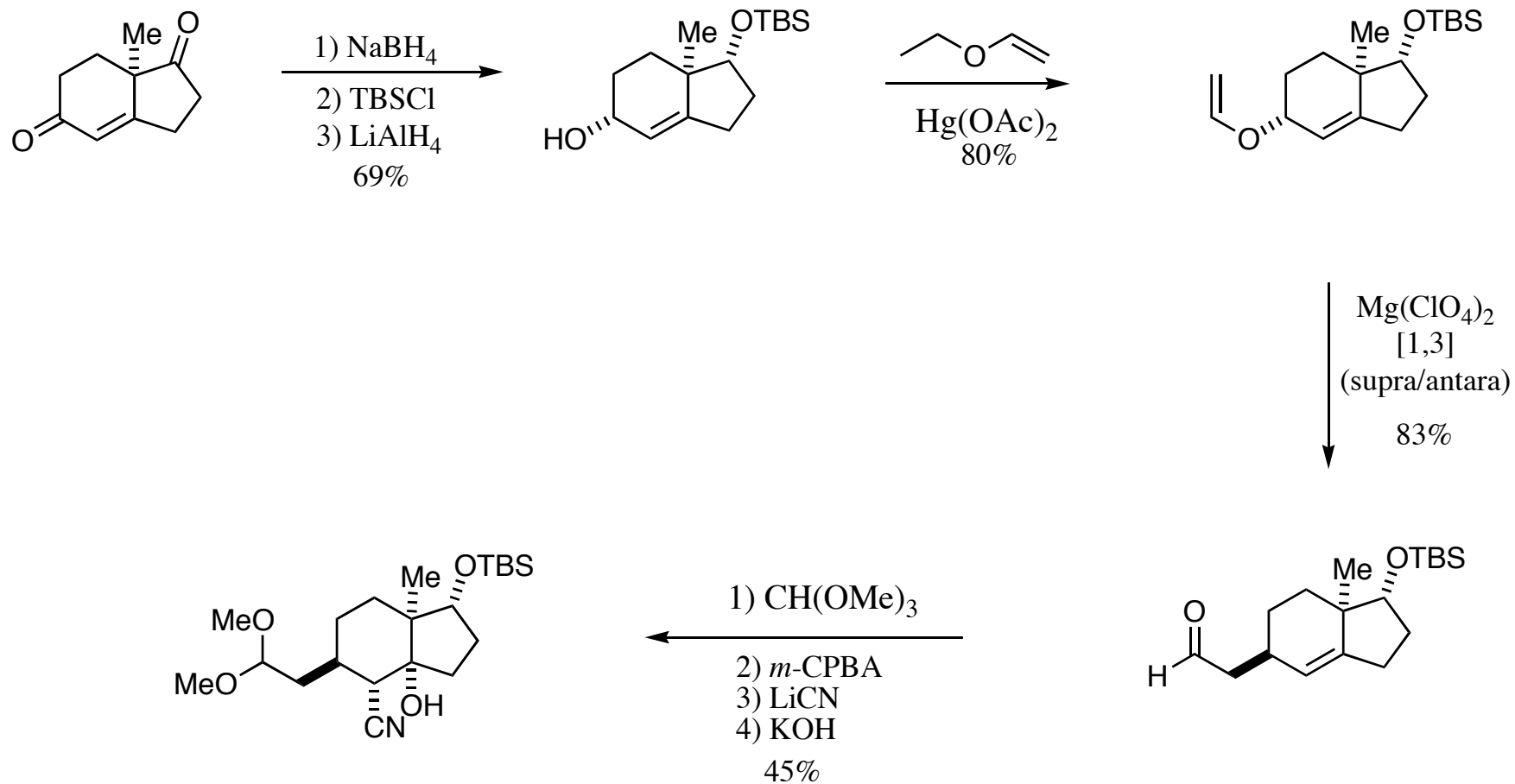

Synthesis of Coraxeniolide-A

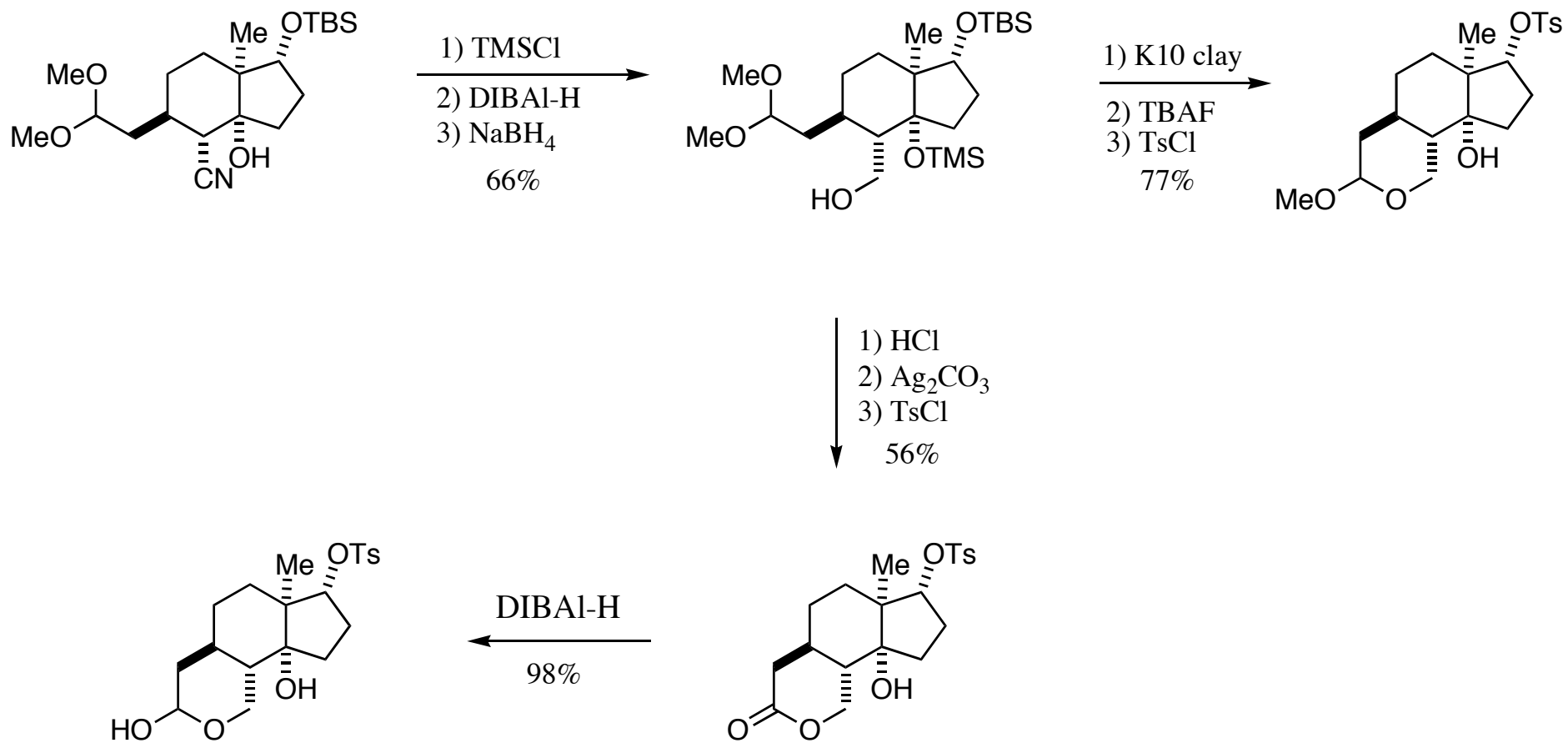

Synthesis of Coraxeniolide-A

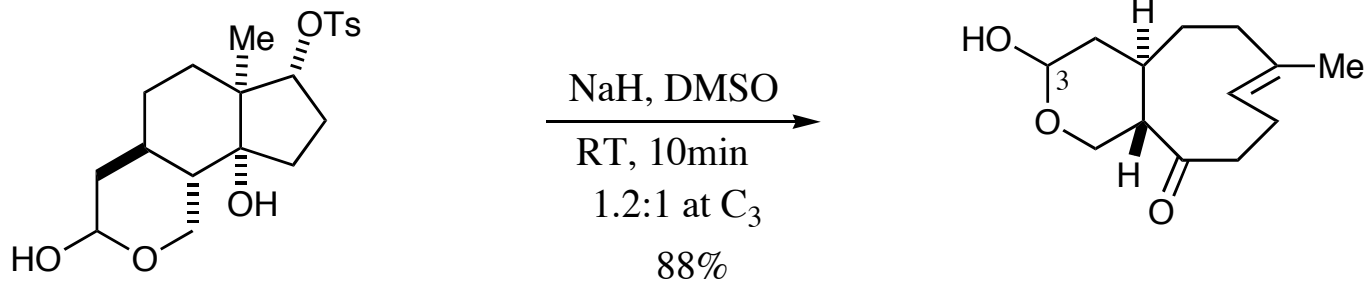
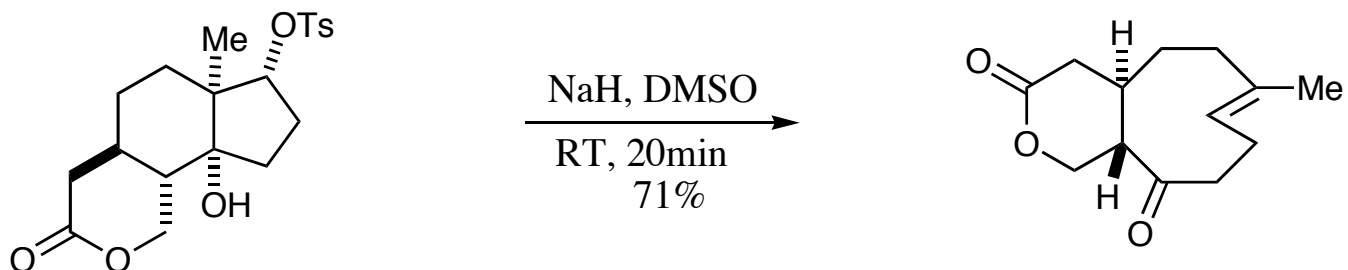
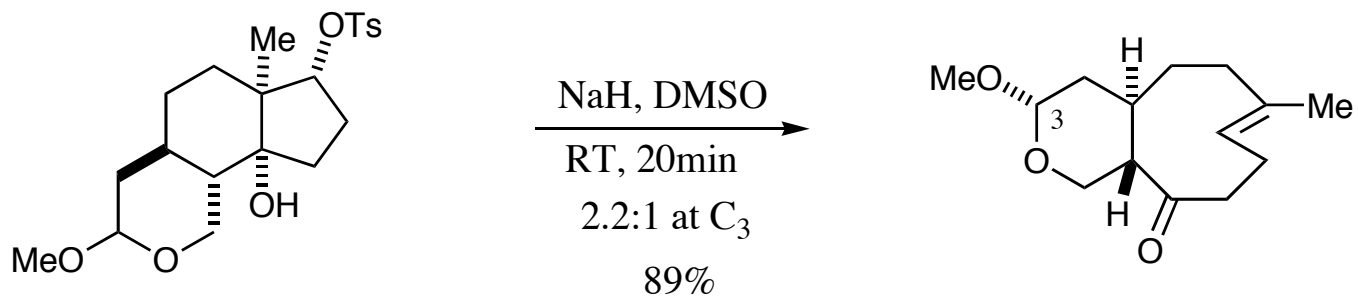

Synthesis of Coraxeniolide-A

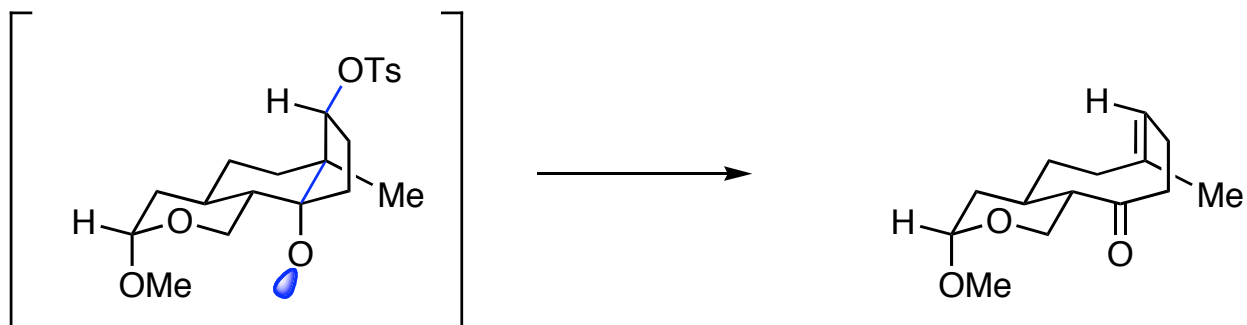
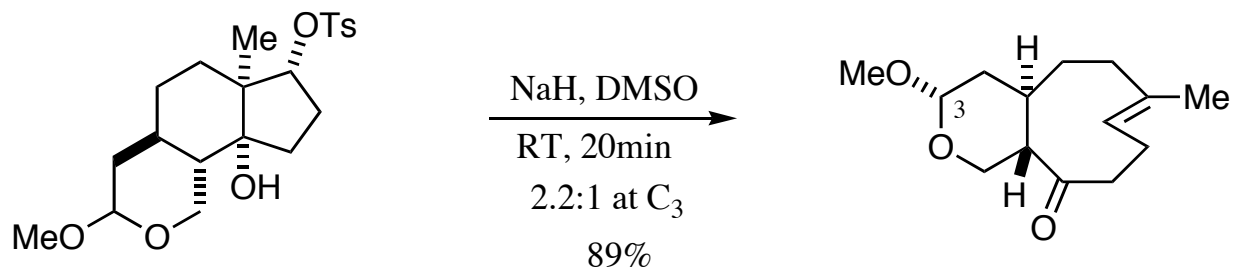

Synthesis of Coraxeniolide-A

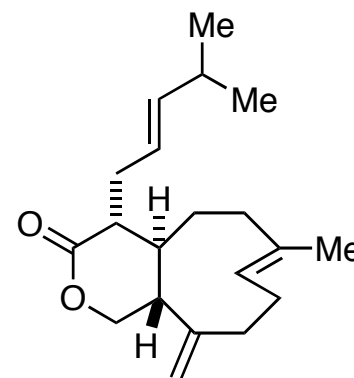
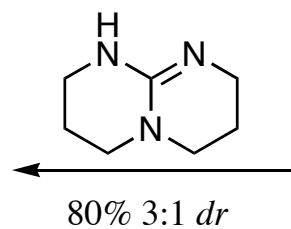
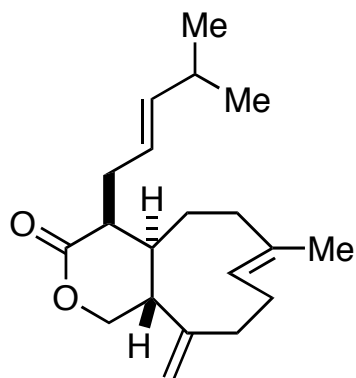
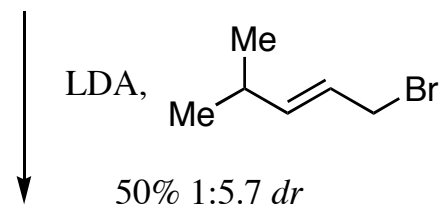
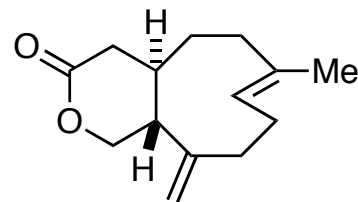
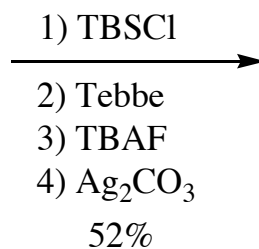
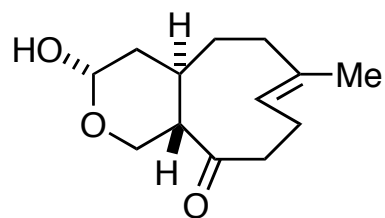

coraxeniolide-A

Progress Towards the Synthesis of CP-263,114

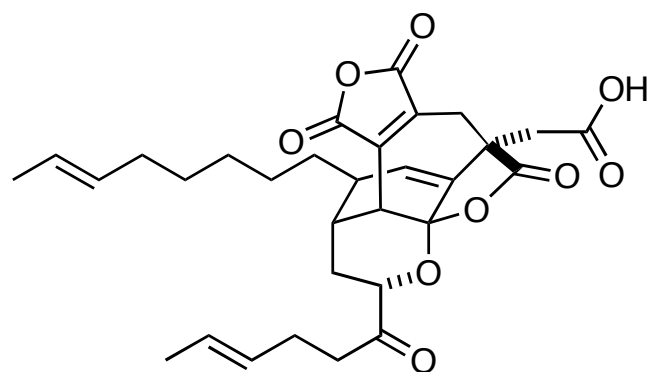

Fragmentation of Isotwistane

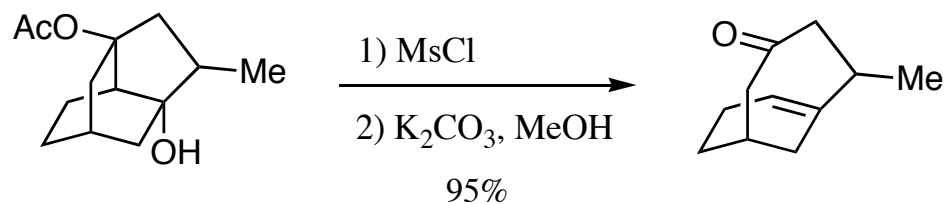

Construction of Quaternary Stereocenter

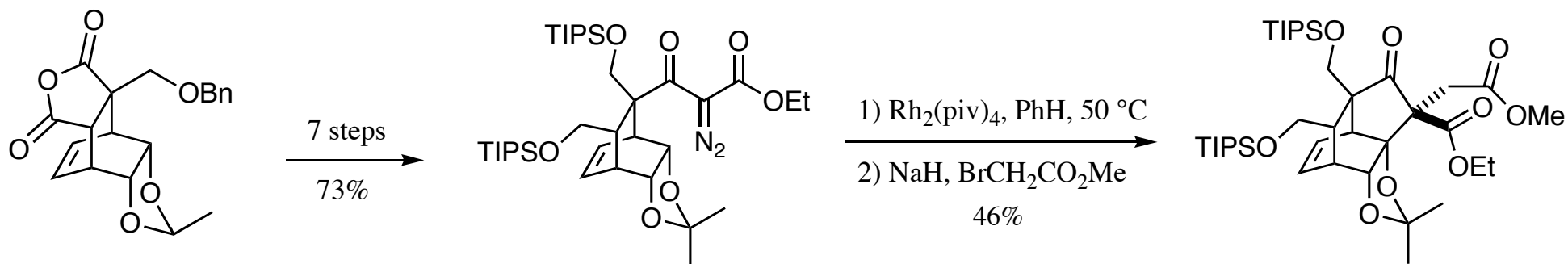

Wood, J. L., *Org. Lett.*, **2001**, *16*, 2431

Wood, J. L., *Tet.*, **2002**, *58*, 6545

Synthesis of Trisubstituted Olefins

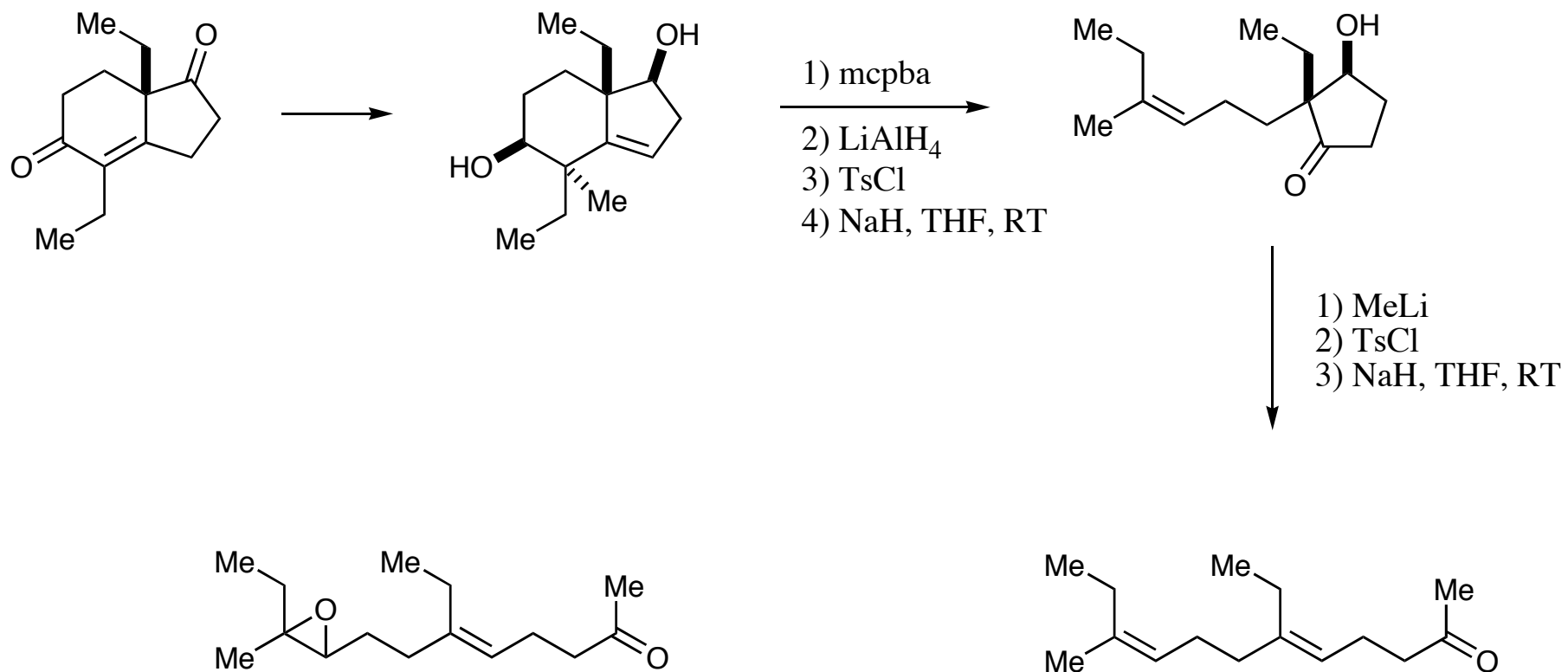

Synthesis of (-)-Epibatidine

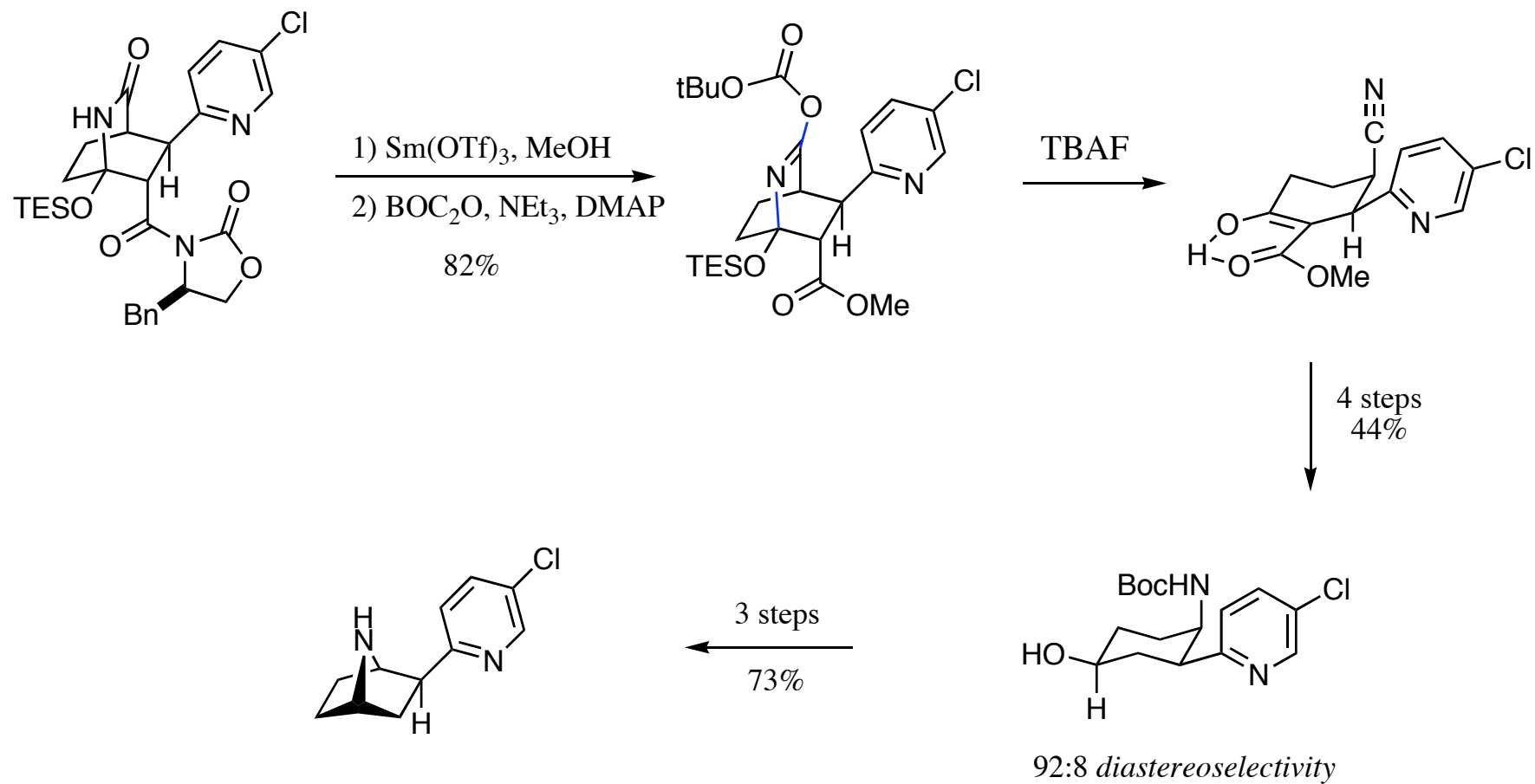

Synthesis of Germacranes

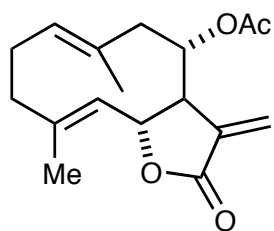

tulipinolide

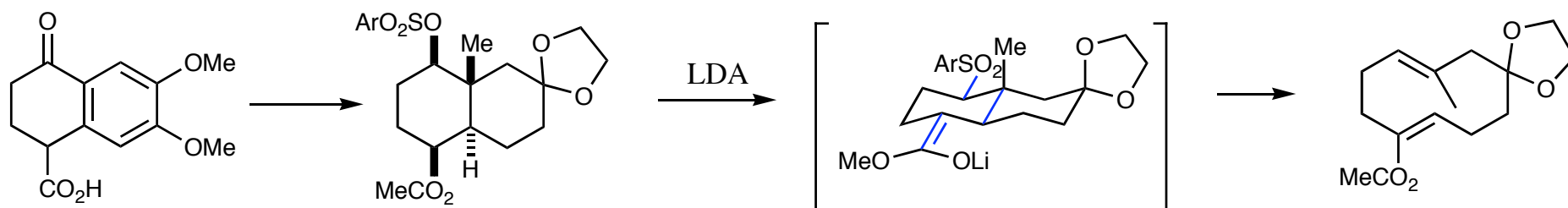
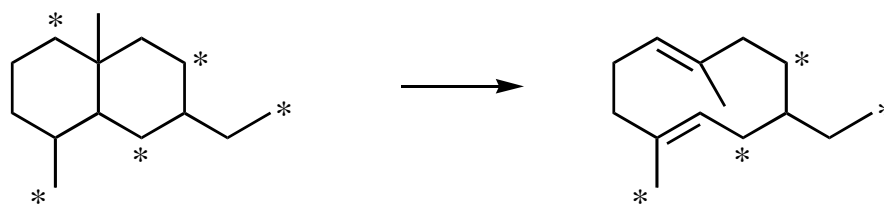

Synthesis of Sericenine

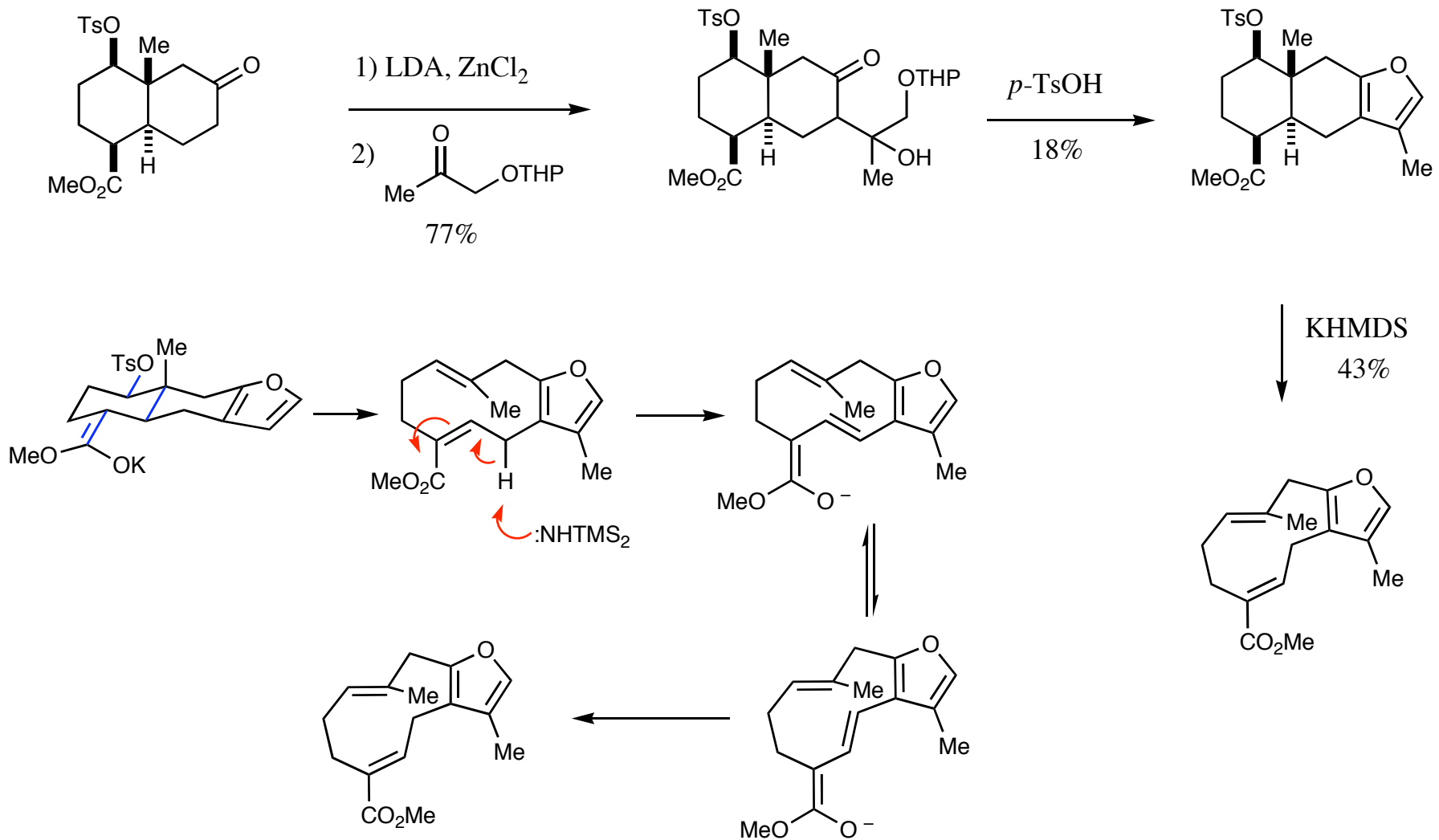

Synthesis of (*E,E*)-Germacranes

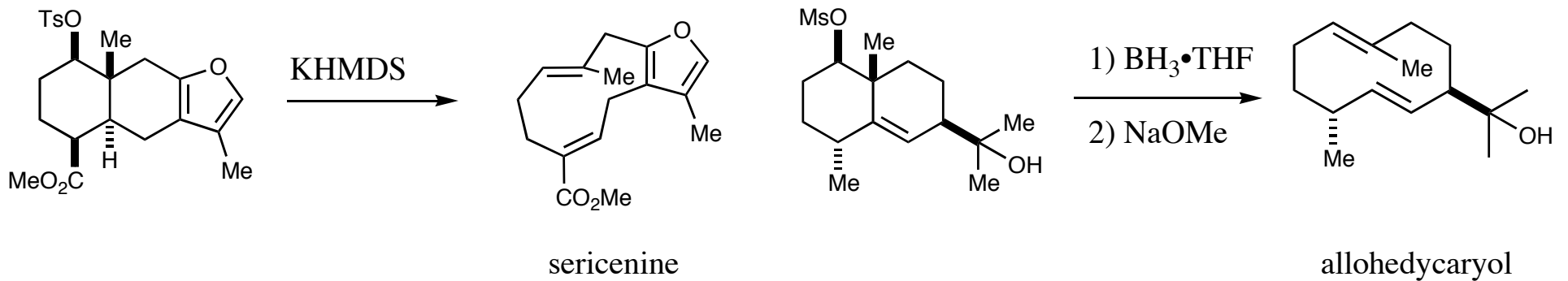
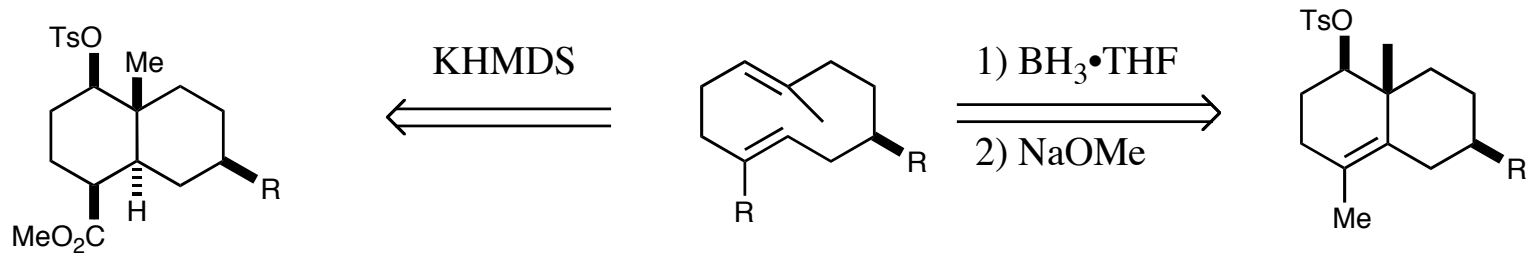

Synthesis of (*E,E*)-Germacranes

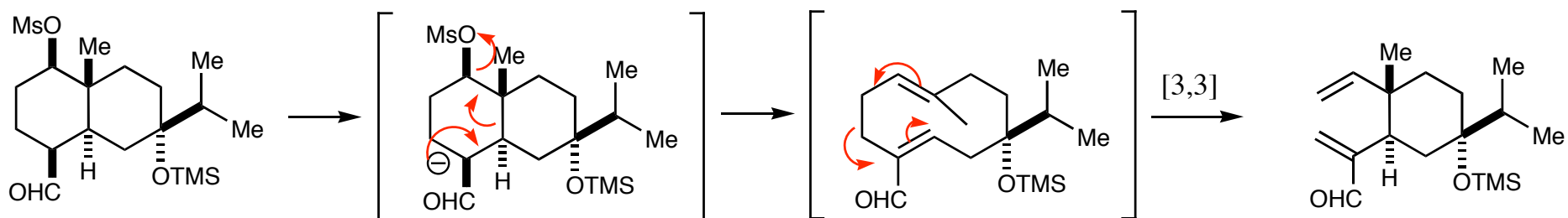
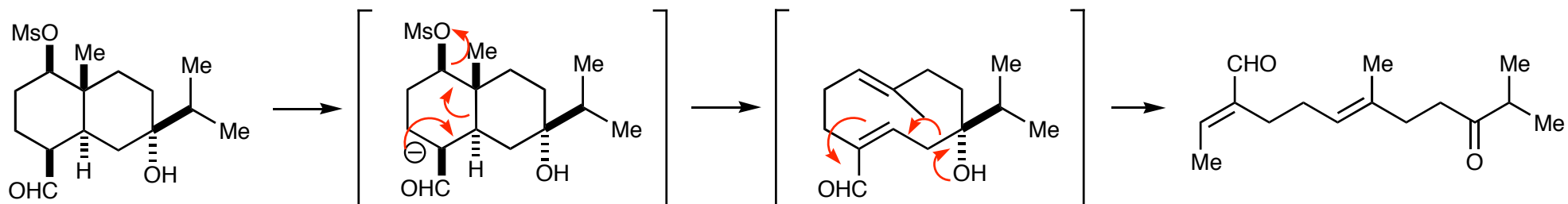

Synthesis of (*E,E*)-Germacranes

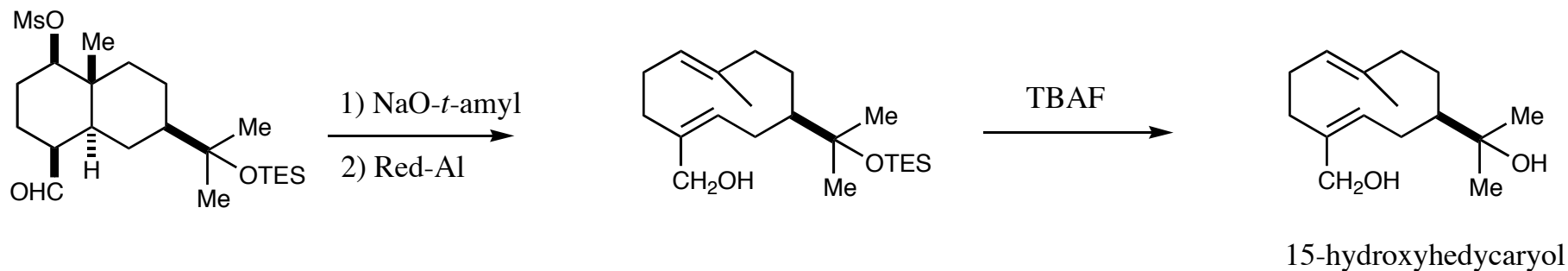
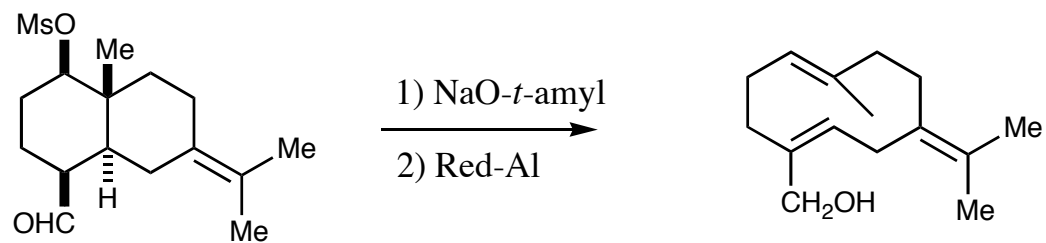
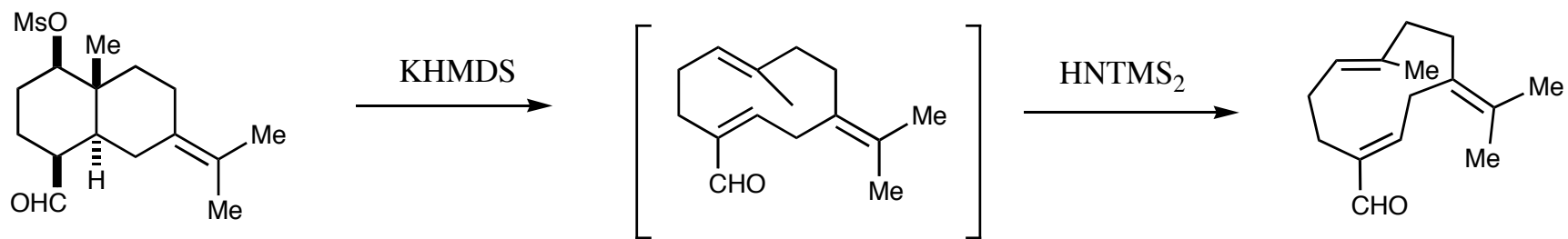

Synthesis of Imidoyl Cyanides

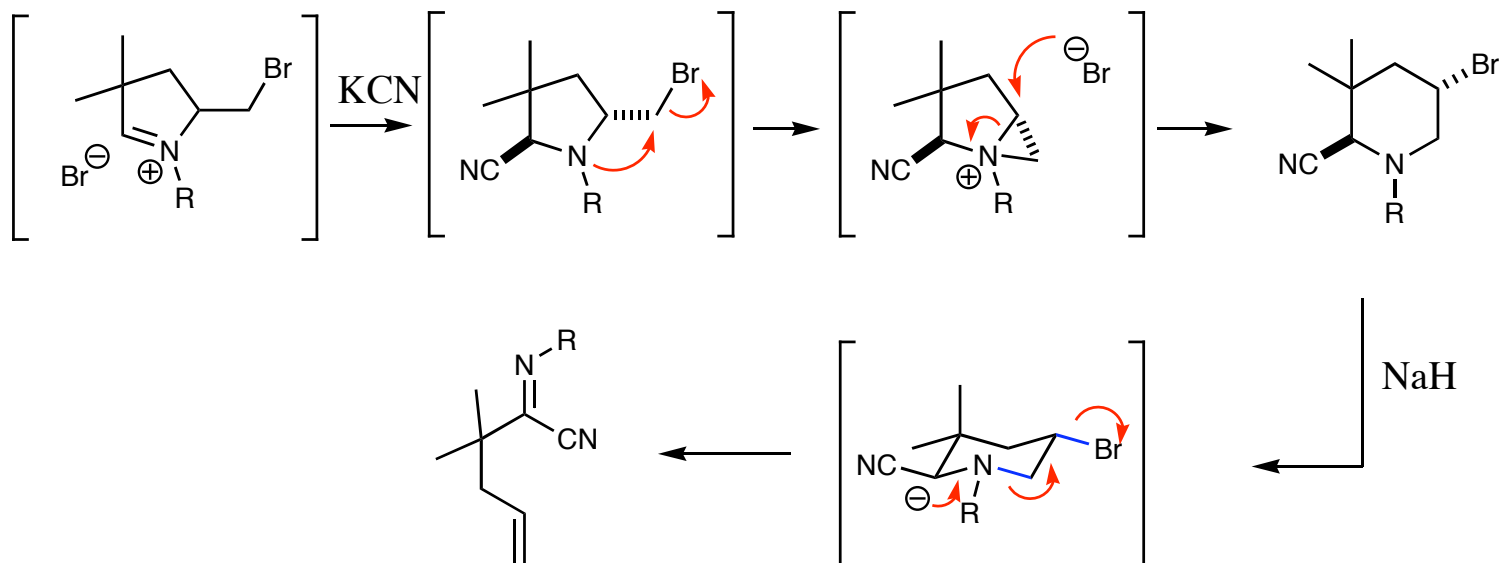
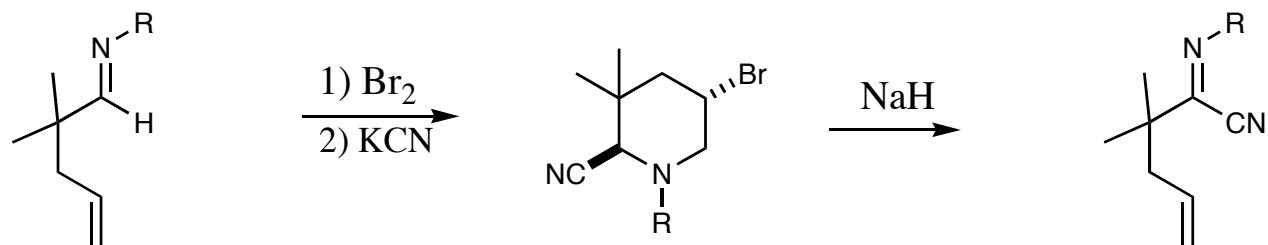

Synthesis of Imidoyl Cyanides

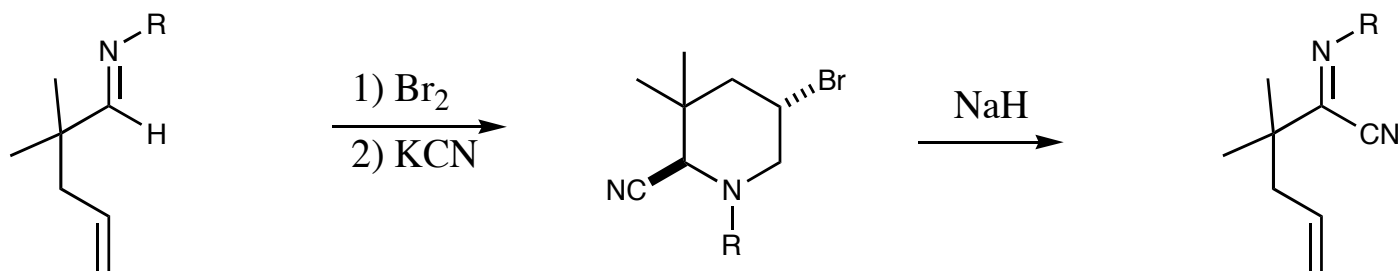

R	Piperidine	Imidoyl Cyanide
<i>cyclo</i> Hexyl	80 %	77 %
(CH ₂) ₂ Ph	71 %	0 %
<i>sec</i> -Bu	70 %	74 %
<i>cyclo</i> Pentyl	77 %	15 %
<i>i</i> -Pr	78 %	82 %
<i>t</i> -Bu	83 %	76 %

Conclusions

- Stereoelectronic requirements for fragmentation reactions

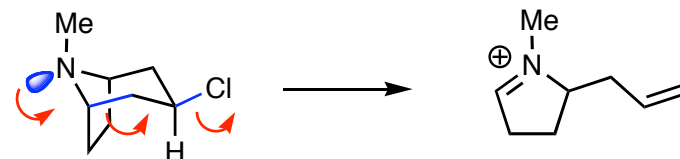

- These types of fragmentation reactions are useful for the synthesis of medium size rings containing olefins

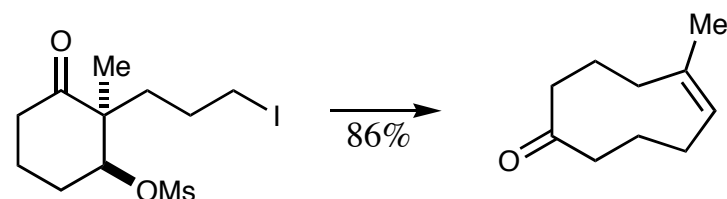

- These types of fragmentation reactions typically occur under very mild conditions (usually RT, with base) and have shown utility in the synthesis of complex natural products

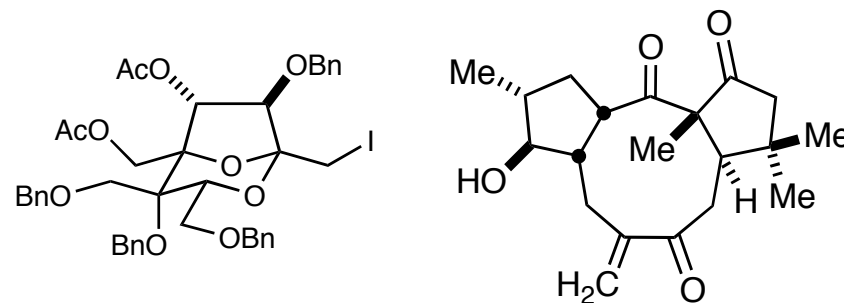

- These types of fragmentation reactions can also be used in the synthesis of other interesting functional groups

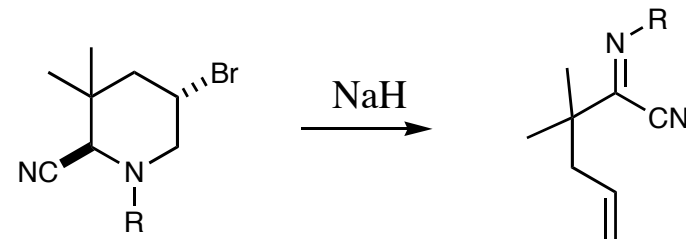

Conclusions

- Stereoelectronic requirements for fragmentation reactions

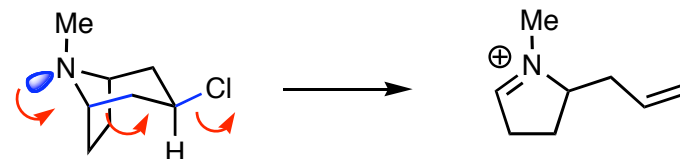

- These types of fragmentation reactions are useful for the synthesis of medium size rings containing olefins

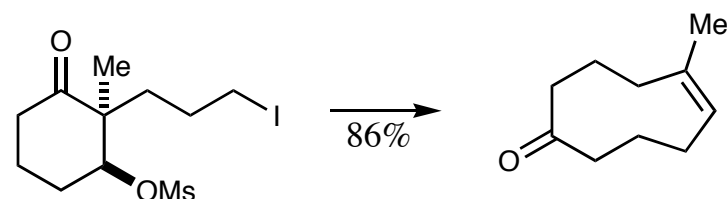

- These types of fragmentation reactions typically occur under very mild conditions (usually RT, with base) and have shown utility in the synthesis of complex natural products

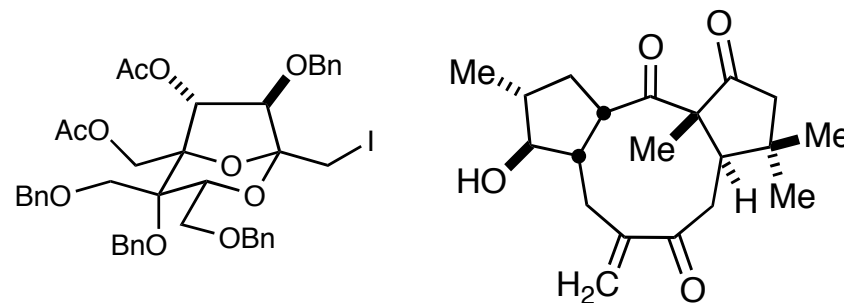

- These types of fragmentation reactions can also be used in the synthesis of other interesting functional groups

